

# HT700



## High Performance SMD TCXO / VCTCXO

High performance TCXO with voltage control option is ideally suited for high performance wireless communications.

### Product description

The HT700/HVT700 combines Rakon's precision IT technology with our superior discrete oscillator performance. This unique hybrid combines 5th order compensation, excellent temperature stability, superb phase noise, with a voltage control option.



### Applications

- WiMAX/WiBro
- LTE
- WLAN
- Basestation
- Communications
- GPS
- IP timing
- SONET/SDH
- Satellite Communication
- DSL/ADSL
- Ethernet
- Other

### Features

- Excellent phase noise performance
- Excellent temperature stability
- Excellent shock and vibration performance
- Improved g performance option available
- Clipped sinewave or CMOS output options
- High frequency option available

### Specifications

#### 1.0 MODEL REFERENCES

Line	Parameter	Description
1.1	Model series	HT700 / HVT700
1.2	RoHS compliant	Yes

**2.0 FREQUENCY CHARACTERISTICS**

Line	Parameter	Test Condition	Value	Unit
2.1	Frequency	Frequency range available (Note 1)	8 to 60	MHz
2.2	Frequency calibration	Offset from nominal frequency measured at 25°C±2°C	±1 max	ppm
2.3	Reflow shift	Two consecutive reflows as per attached profile after 1 hour recovery at 25°C	±1 max	ppm
2.4	Frequency stability over temperature	Referenced to the midpoint between minimum and maximum frequency value over the specified temperature range (Note 2 & 3)	±0.18 to 5	ppm
2.5	Temperature range	The operating temperature range over which the frequency stability is measured (Note 4)	-40 to 85	°C
2.6	Frequency slope	Minimum of 1 frequency reading every 2°C, over the operating temperature range (Note 3)	0.05 to 0.5	ppm/°C
2.7	Static temperature hysteresis	Frequency change after reciprocal temperature ramped over the operating range. Frequency measured before and after 25°C	±0.4 max	ppm
2.8	Supply voltage stability	Supply voltage varied ±5% at 25°C	±0.05 max	ppm
2.9	Load sensitivity	Frequency change when the specified load is varied ±10% measured at 25°C	±0.4 max	ppm
2.10	Long term stability	Frequency drifts over 1 year at 25°C	±1 max	ppm
2.11	G Sensitivity	Gamma vector of all three axes from 30 Hz to 1500 Hz (Note 5 & 6)	0.3 to 3	ppb/G
2.12	Root Allan Variance	1 second averaging time (Tau) (Note 7)	0.5 max	ppb
2.13	Start-up time (amplitude)	Time taken for output to reach 90% of specified output level.	5 max	ms
2.14	Settling time (frequency)	Time taken for frequency to reach specified calibration tolerance (Note 8)	7 min	ms

**3.0 POWER SUPPLY CHARACTERISTICS**

Line	Parameter	Test Condition	Value	Unit
3.1	Supply voltage	Nominal supply voltage range	2.7 to 5.5	V
3.2	Supply current	Nominal supply current measured at maximum supply voltage and load condition specified in output section (Note 9)	4 to 10	mA

**4.0 CONTROL VOLTAGE (VCO) OPTION**

Line	Parameter	Test Condition	Value	Unit
4.1	Control voltage range	1.5V mid VCO (Note 10)	0.5 to 2.5	V
4.2	Control voltage range	1.65V mid VCO (Note 10)	0.5 to 2.8	V
4.3	Control voltage range	2.5V mid VCO (Note 10)	0.5 to 4.5	V
4.4	Frequency tuning range	Frequency shift from minimum to maximum control voltages	10 to 30	ppm
4.5	Frequency tuning linearity	Deviation from straight line curve fit	10 max	%
4.6	Voltage control pin input impedance		100 min	kΩ

**5.0 CLIPPED SINE WAVE OSCILLATOR OUTPUT**

Line	Parameter	Test Condition	Value	Unit
5.1	Output waveform	AC coupled clipped sine-wave		
5.2	Output voltage level	Peak-to-peak voltage measured at minimum supply voltage and load conditions specified (Note 9)	0.6 min	V
5.3	Output load resistance	Operating range	9 to 11	kΩ
5.4	Output load capacitance	Operating range	9 to 11	pF

**6.0 CMOS OSCILLATOR OUTPUT**

Line	Parameter	Test Condition	Value	Unit
6.1	Output waveform	HCMOS		
6.2	Output voltage level low	Measured with a capacitive load of 10pF	10 max	%Vcc
6.3	Output voltage level high	Measured with a capacitive load of 10pF	90 min	%Vcc
6.4	Rise and fall times	Measured with a capacitive load of 10pF	3 max	ns
6.5	Duty cycle	Measured at 50% Vcc trigger level	40 to 60	%
6.6	Output load		10 max	pF

**7.0 SSB PHASE NOISE**

Line	Parameter	Test Condition	Value	Unit
7.1	SSB phase noise power density at 1 Hz offset	Typical value for a 10.0 MHz oscillator at 25°C (Note 11)	-65	dBc/Hz
7.2	SSB phase noise power density at 10 Hz offset	Typical value for a 10.0 MHz oscillator at 25°C (Note 11)	-95	dBc/Hz
7.3	SSB phase noise power density at 100 Hz offset	Typical value for a 10.0 MHz oscillator at 25°C (Note 11)	-132	dBc/Hz
7.4	SSB phase noise power density at 1 kHz offset	Typical value for a 10.0 MHz oscillator at 25°C (Note 11)	-142	dBc/Hz
7.5	SSB phase noise power density at 10 kHz offset	Typical value for a 10.0 MHz oscillator at 25°C (Note 11)	-147	dBc/Hz
7.6	SSB phase noise power density at 100 kHz offset	Typical value for a 10.0 MHz oscillator at 25°C (Note 11)	-150	dBc/Hz

**8.0 ENVIRONMENTAL INFORMATION**

Line	Parameter	Description
8.1	Shock	Half sine-wave acceleration of 100G peak amplitude for 6ms duration, 3 cycles each plane. IEC 60068-2-27
8.2	Random vibration	5G RMS 30Hz to 1500Hz duration of 6 hours per axis
8.3	Humidity	85% relative non-condensing humidity for 48 hours at 85°C
8.4	Thermal shock	-40°C for 30 minutes followed by 85°C for 30 minutes, continuously cycled for 5 days
8.5	Storage temperature	-40°C to 85°C

**9.0 MARKING**

Line	Parameter	Description
9.1	Line 1	Pin 1 and Rakon
9.2	Line 2	Model part number
9.3	Line 3	Frequency in MHz
9.4	Line 4	Date code (WWYY)

**10.0 MANUFACTURING INFORMATION**

Line	Parameter	Description
10.1	Washing	Not recommended for aqueous washing process
10.2	Packaging	Refer to packaging information. Standard packing quantity is 250 units per reel
10.3	Soldering	Able to withstand normal lead free convection reflow process. Not suitable for inverted reflow

**11.0 SPECIFICATION NOTES**

Line	Parameter	Description
11.1	Note 1	Frequencies below 8.0MHz are only available with HCMOS output.
11.2	Note 2	A maximum frequency stability over the temperature is required to be specified. Standard options are $\pm 0.3\text{ppm}$ , $\pm 0.5\text{ppm}$ , $\pm 1.0\text{ppm}$ , and $\pm 2.5\text{ppm}$ .
11.3	Note 3	Part should be shielded from drafts causing unexpected thermal gradients. Temperature changes due to ambient air currents on the oscillator can lead to short term frequency drift.
11.4	Note 4	The operating temperature range needs to be specified. The extremes for this model are -40 to 85°C.
11.5	Note 5	The maximum value is the specification. A minimum value, if present, indicates the best specification available.
11.6	Note 6	Specifications $< 1.0\text{ppb/G}$ require the use of the Rakon RGX Hi-G crystal. H-G crystal are available for frequencies between 10.0 and 26.0MHz.
11.7	Note 7	Specifications below 0.5 ppb may require additional screening processes.
11.8	Note 8	Specification assumes that no special phase noise filtering is required. If low phase noise is required then the frequency settling time will increase. Full details are available from Rakon Sales.
11.9	Note 9	Exact figure will be frequency, supply voltage and output option dependant.
11.10	Note 10	3 options are available. Please specify one option only. Using 1.5V mid-VCO will result in a lower pull range. VCO of 4.5V only applicable with a Vcc of 5.0V.
11.11	Note 11	For specific frequency phase noise, please consult your Rakon Sales office for more information.

**Drawing Name: H(V)T700 Series Model Drawing**

**MODEL OUTLINE**

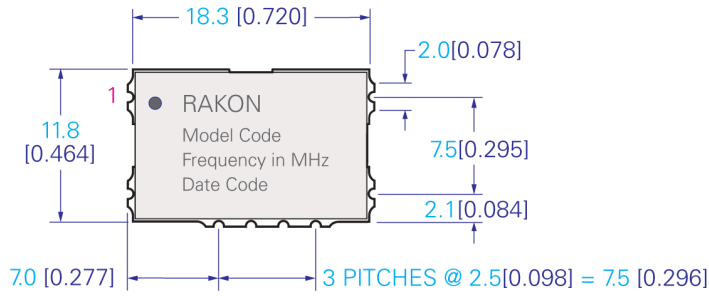

TOP VIEW

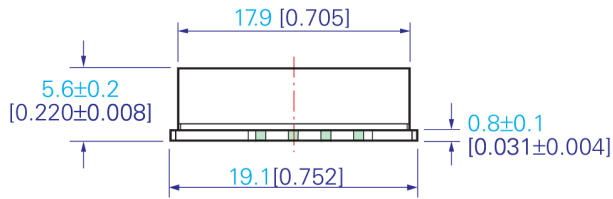

SIDE VIEW

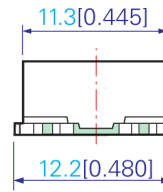

END VIEW

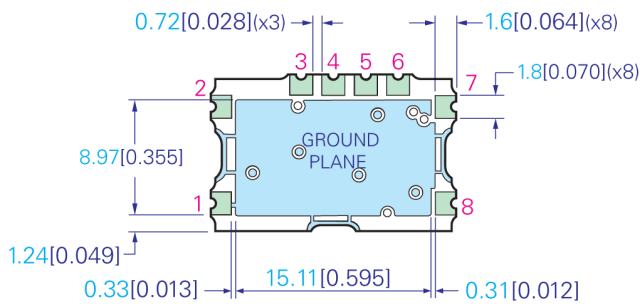

BOTTOM VIEW

**PIN CONNECTIONS**

PIN	HT	HVT
1	GND	GND
2	RF OUTPUT	RF OUTPUT
3	NC	NC
4	NC	NC
5	NC	NC
6	NC	NC
7	VCC	VCC
8	NC	VCO

**RECOMMENDED PAD LAYOUT - TOP VIEW**

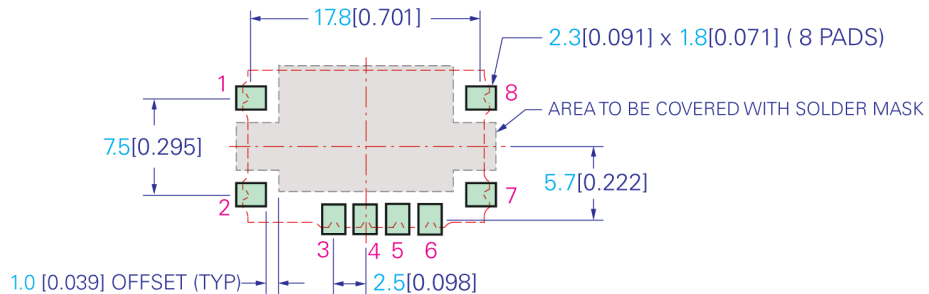

TITLE: H(V)T700 SERIES MODEL

RELATED DRAWINGS:

FILENAME: CAT358

REVISION: E

DATE: 12-Jan-11

SCALE: 2 : 1

Millimetres [inch]

Tolerance:

XX = ±0.5

X.X = ±0.2

X.XX = ±0.10

X.XXX = ±0.05

X<sup>0</sup> = ±1.0°

Hole = ±0.10



©2009 Rakon Limited

**Drawing Name: H(V)T700 Series Test Circuit**

HT INPUT:

C<sub>1</sub>: 100nF  
 F<sub>1</sub>: A ferrite bead or a resistor between  
 22Ω~ 47Ω recommended.

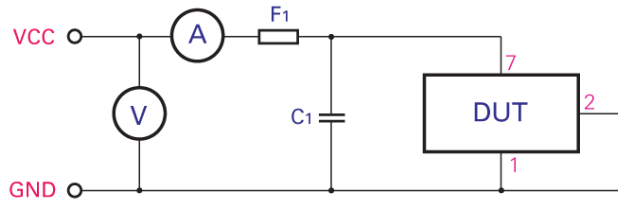

HVT INPUT:

C<sub>1</sub>: 100nF  
 F<sub>1</sub>: A ferrite bead or a resistor between  
 22Ω~ 47Ω recommended.

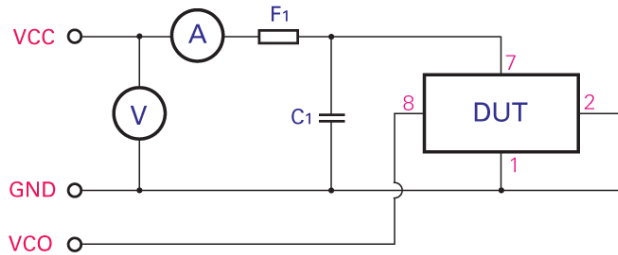

CLIPPED SINEWAVE OUTPUT:

R<sub>L</sub>: 10K  
 $C_T = C_L + C_2$  (C<sub>2</sub> - Oscilloscope probe capacitance)  
 C<sub>T</sub> as stated in OSCILLATOR OUTPUT section

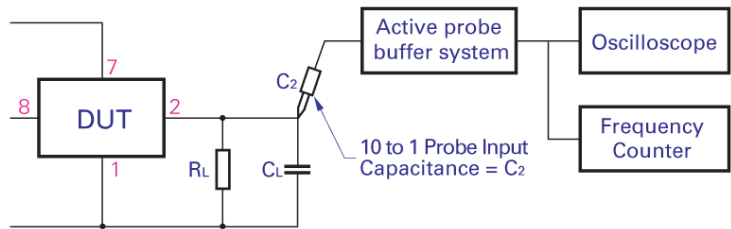

CMOS OUTPUT:

$C_T = C_L + C_2$  (C<sub>2</sub> - Oscilloscope probe capacitance)  
 C<sub>T</sub> as stated in OSCILLATOR OUTPUT section

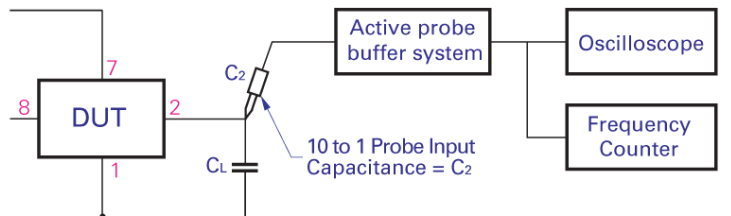

TITLE: H(V)T700 SERIES TEST CIRCUIT

FILENAME: CAT360

RELATED DRAWINGS:

REVISION: C

DATE: 16-Aug-10

SCALE: NTS

Millimetres [inch]



©2009 Rakon Limited

**Drawing Name: H(V)T700 Series Tape & Reel**

**TAPE DETAIL (SCALE 1 : 1)**

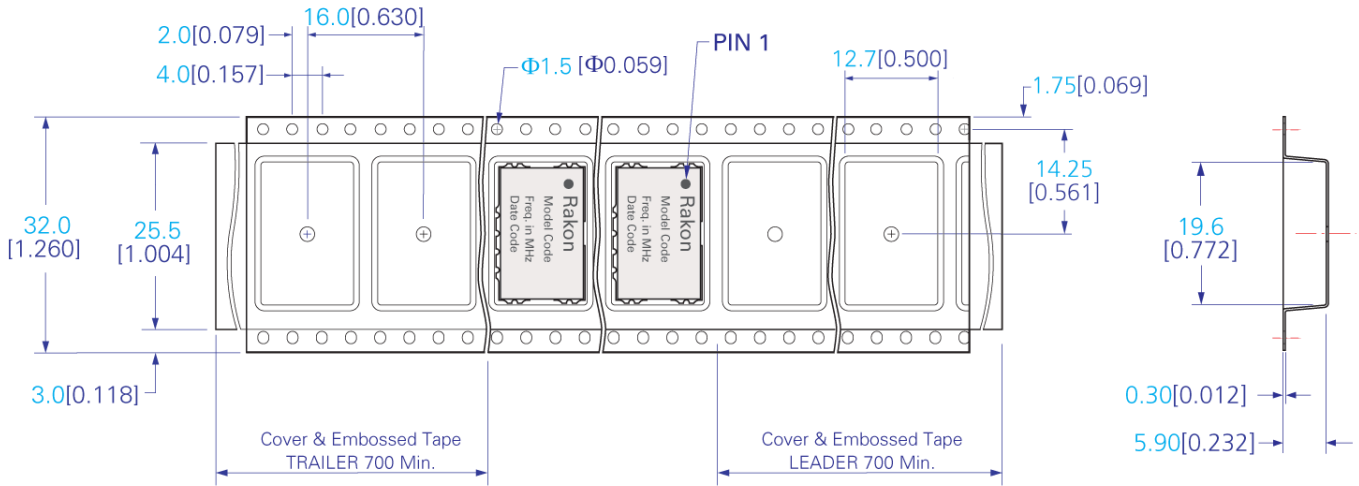

**REEL DETAIL (SCALE 1 : 5)**

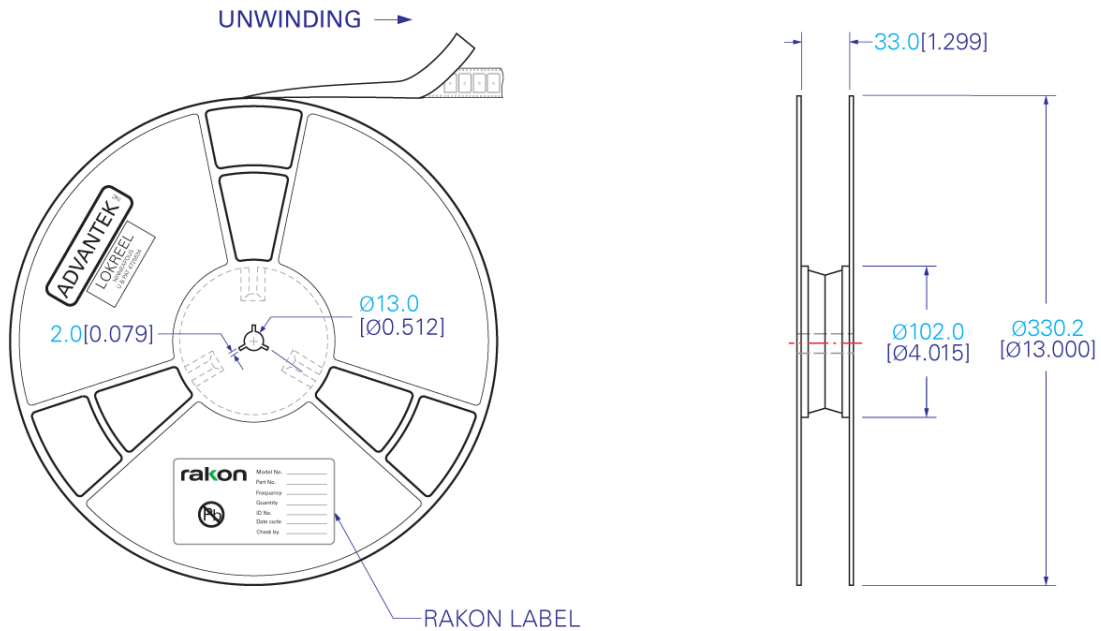

TITLE: H(V)T700 SERIETAPE & REEL

FILENAME: CAT099

Tolerance:

RELATED DRAWINGS:

REVISION: C

XX =  $\pm 0.5$

X.X =  $\pm 0.2$

X.XX =  $\pm 0.10$

X.XXX =  $\pm 0.05$

X<sup>o</sup> =  $\pm 1.0^{\circ}$

Hole =  $\pm 0.10$

DATE: 05-Aug-10

SCALE: See Above

Millimetres [inch]

**rakon**

©2009 Rakon Limited

**Drawing Name: Pb-Free Reflow**

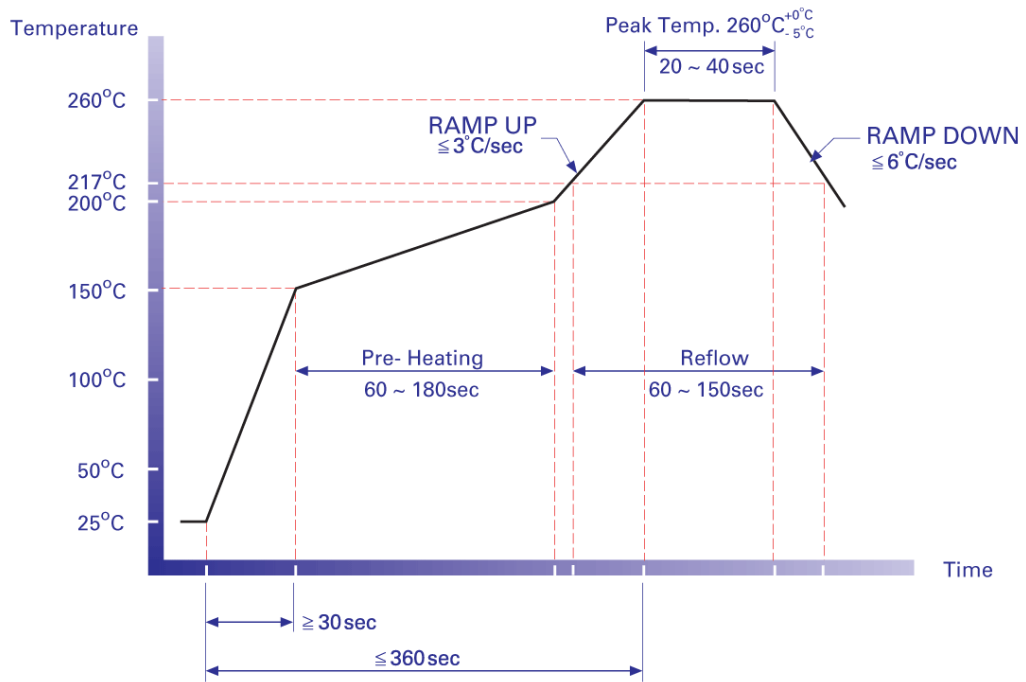

**NOTE:**

The product has been tested to withstand the Reflow Profile shown. The Reflow Profile used to solder Rakon products is determined by the solder paste manufacturer's specification. It is recommended that the Reflow Profile used does not exceed the one shown above.

TITLE: Pb-FREE REFLOW

RELATED DRAWINGS:

FILENAME: CAT541

REVISION: B

DATE: 07-Apr-10

SCALE: NTS

Millimetres [inch]



©2009 Rakon Limited

## Specification History

**Current Version : 1.01**

Version	User	Change	Note	Date
---------	------	--------	------	------