

IT2200W

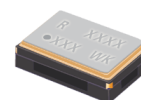

SMD TCXO with low phase noise.

Low cost SMD TCXO with voltage control option, using an analogue IC for compensation and low phase noise. Frequency range from 10.0 MHz to 52.0 MHz.



Product description

The I(V)T2200W employs an analogue IC for the oscillator and temperature compensation in an industry standard 2.5 mm x 2.0 mm package. The compensation circuitry and oscillator design are optimized to minimize their contribution to phase noise.

Applications

- Handset
- Consumer Products
- GPS
- Other
- PND
- WiFi

Features

- Frequency slope and perturbation specifications can be customized to the application requirement
- Clipped sine-wave output
- Low cost
- Standard temperature stability choices are ± 1.0 ppm over -10°C to 60°C , ± 2.0 ppm over -30°C to 85°C .

Specifications

1.0 SPECIFICATION REFERENCES

Line	Parameter	Description
1.1	Model Description	IT2200W / IVT2200W (Draft)
1.2	RoHS Compliant	Yes

2.0 FREQUENCY CHARACTERISTICS

Line	Parameter	Test Condition	Value	Unit
2.1	Frequency range	Frequency	10 to 52	MHz
2.2	Frequency calibration	Offset from nominal frequency measured at $25^{\circ}\text{C} \pm 2^{\circ}\text{C}$	± 1 max	ppm
2.3	Reflow shift	Two consecutive reflows as per attached profile after 1 hour recovery	± 1 max	ppm
2.4	Frequency stability over temperature	Referenced to the midpoint between minimum and maximum frequency value over the specified temperature range. Control voltage set to midpoint of control voltage (Note 1, 2)	± 0.5 to 5	ppm
2.5	Temperature range	The operating temperature range over which the frequency stability is measured (Note 3)	-30 to 85	$^{\circ}\text{C}$
2.6	Frequency slope	Minimum of 1 frequency reading every 2°C , over the operating temperature range (Note 1, 2, 4)	0.05 to 1	ppm/ $^{\circ}\text{C}$
2.7	Static temperature hysteresis	Frequency change after reciprocal temperature ramped over the operating range. Frequency measured before and after at 25°C	0.6 max	ppm
2.8	Supply voltage stability	Supply voltage varied $\pm 5\%$ at 25°C (Note 4)	± 0.2 max	ppm
2.9	Load sensitivity	$\pm 5\%$ load change	± 0.2 max	ppm
2.10	Long term stability	Frequency drift over 1 year (Note 4)	± 1 max	ppm

3.0 POWER SUPPLY

Line	Parameter	Test Condition	Value	Unit
3.1	Supply voltage	Nominal supply voltage range (Note 5)	2.28 to 3.7	V
3.2	Current	At maximum supply voltage (Note 6)	2 max	mA

4.0 CONTROL VOLTAGE (VCO) OPTIONAL

Line	Parameter	Test Condition	Value	Unit
4.1	Control voltage	The nominal control voltage value is midway between the minimum and maximum (Note 7)	0.5 to 2.8	V
4.2	Frequency tuning	Frequency shift from minimum to maximum control voltages (Note 8)	6 to 50	ppm
4.3	Port input impedance	Measured between Control voltage and GND pin	500 min	kOhm

5.0 OSCILLATOR OUTPUT

Line	Parameter	Test Condition	Value	Unit
5.1	Output waveform	DC coupled clipped sinewave (Note 9)		
5.2	Output voltage level	At minimum supply voltage (Note 6)	0.8 min	V
5.3	Output load resistance	Refer test circuit	9.5 to 10.5	kOhm
5.4	Output load capacitance	Refer test circuit	9.5 to 10.5	pF

6.0 SSB PHASE NOISE

Line	Parameter	Test Condition	Value	Unit
6.1	SSB phase noise power density at 1Hz offset	Typical value for a 19.2 MHz oscillator at 25°C	-70	dBc/Hz
6.2	SSB phase noise power density at 10Hz offset	Typical value for a 19.2 MHz oscillator at 25°C	-94	dBc/Hz
6.3	SSB phase noise power density at 100Hz offset	Typical value for a 19.2 MHz oscillator at 25°C	-119	dBc/Hz
6.4	SSB phase noise power density at 1KHz offset	Typical value for a 19.2 MHz oscillator at 25°C	-140	dBc/Hz
6.5	SSB phase noise power density at 10KHz offset	Typical value for a 19.2 MHz oscillator at 25°C	-149	dBc/Hz
6.6	SSB phase noise power density at 100KHz offset	Typical value for a 19.2 MHz oscillator at 25°C	-150	dBc/Hz

7.0 ENVIRONMENTAL

Line	Parameter	Description
7.1	Shock	Half sine-wave acceleration of 100G peak amplitude for 6ms duration, 3 cycles each plane.
7.2	Humidity	After 48 hours at 85°C ± 2°C 85% relative humidity non-condensing.
7.3	Thermal shock	Exposed at -40°C for 30 minutes then at 85°C for 30 minutes constantly for a period of 5 days.
7.4	Vibration	10G RMS from 30Hz to 1500Hz random in each of the 3 axis for 4 hours, total 12 hours.
7.5	Storage temperature	-40°C to 85°C.

8.0 MARKING

Line	Parameter	Description
8.1	Type	Engraved.
8.2	Line 1	R and Product code.
8.3	Line 2	Pin 1 and Date code.

9.0 MANUFACTURING INFORMATION

Line	Parameter	Description
9.1	Reflow	Solder reflow process as per profile attached.
9.2	Packaging description	Tape and reel. Standard packing quantity is 3000 units per reel

10.0 SPECIFICATION NOTES

Line	Parameter	Description
10.1	Note 1	A maximum frequency stability over the temperature is required to be specified. Values between ± 0.3 and ± 10 ppm are available. Standard options are ± 0.5 ppm, ± 1.0 ppm, ± 1.5 ppm and ± 2.0 ppm.
10.2	Note 2	Parts should be shielded from drafts causing unexpected thermal gradients. Temperature changes due to ambient air currents on the oscillator can lead to short term frequency drift.
10.3	Note 3	The operating temperature range needs to be specified. The extremes for this model are -30°C to 85°C .
10.4	Note 4	The maximum value is the specification. A minimum value, if present, indicates the best specification available.
10.5	Note 5	The unit will operate on any voltage between minimum and maximum values.
10.6	Note 6	Specified for load stated in 5.3 and 5.4 at 25°C .
10.7	Note 7	Voltage control should not exceed $V_{cc} - 0.2\text{V}$ or below $\text{GND} + 0.2\text{V}$
10.8	Note 8	The maximum frequency tuning range depends on the design frequency and the trimming sensitivity of the crystal. Linearity performance degrades if maximum frequency tuning setting is selected.
10.9	Note 9	External AC-Coupling capacitor required. 1nF or greater recommended.

Preliminary

Drawing Name: I(V)T2200W Model Drawing

MODEL OUTLINE

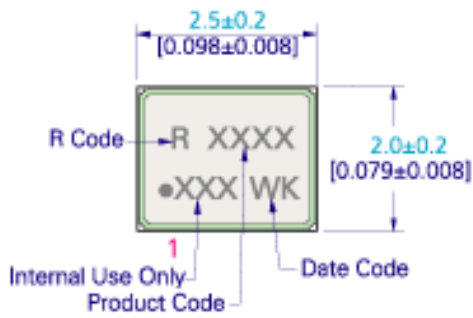

TOP VIEW



SIDE VIEW



END VIEW

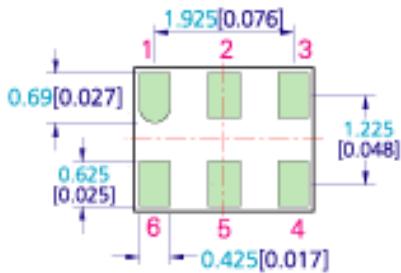

BOTTOM VIEW

PIN CONNECTION

Pin	IT	IVT
1	NC	VCO
2	NC	NC
3	GND	GND
4	OUTPUT	OUTPUT
5	NC	NC
6	VCC	VCC

RECOMMENDED PAD LAYOUT - TOP VIEW

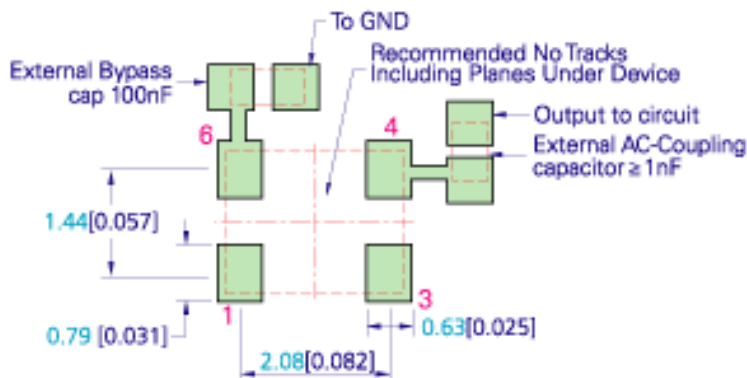

TITLE: I(V)T2200W MODEL

RELATED DRAWINGS:

FILENAME: CAT118

REVISION: A

DATE: 16-Apr-09

SCALE: 10 : 1

Millimetres [inch]

Tolerance:

XX = ±0.5

X.X = ±0.2

X.XX = ±0.10

X.XXX = ±0.05

X° = ±1.0°

Hole = ±0.10



©2009 Rakon Limited

Drawing Name: I(V)T2200 Series Test Circuit

IT TEST CIRCUIT :

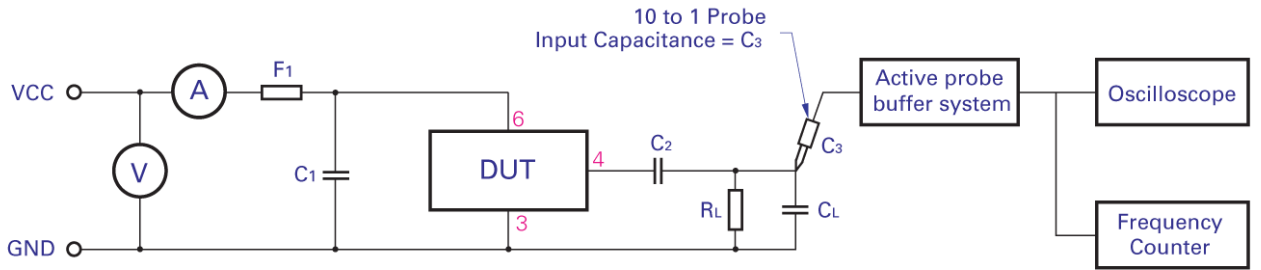

IVT TEST CIRCUIT :

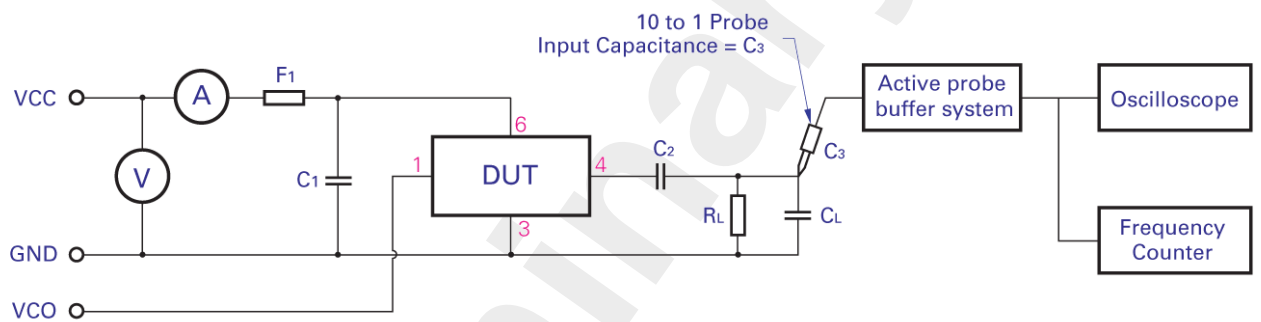

C_1 : 100nF

C_2 : ≥ 1 nF

R_L : 10K

$C_T = C_L + C_3$ (C_3 - Oscilloscope probe capacitance)

C_T as stated in OSCILLATOR OUTPUT section

F_1 : A ferrite bead or a resistor between $22\Omega \sim 47\Omega$ recommended.

TITLE: I(V)T2200 SERIES TEST CIRCUIT

FILENAME: CAT421

RELATED DRAWINGS:

REVISION: D

DATE: 16-Apr-09

SCALE: NTS

Millimetres [inch]

rakon

©2009 Rakon Limited

Drawing Name: 2200 Series Tape & Reel

TAPE DETAIL (SCALE 5 : 1)

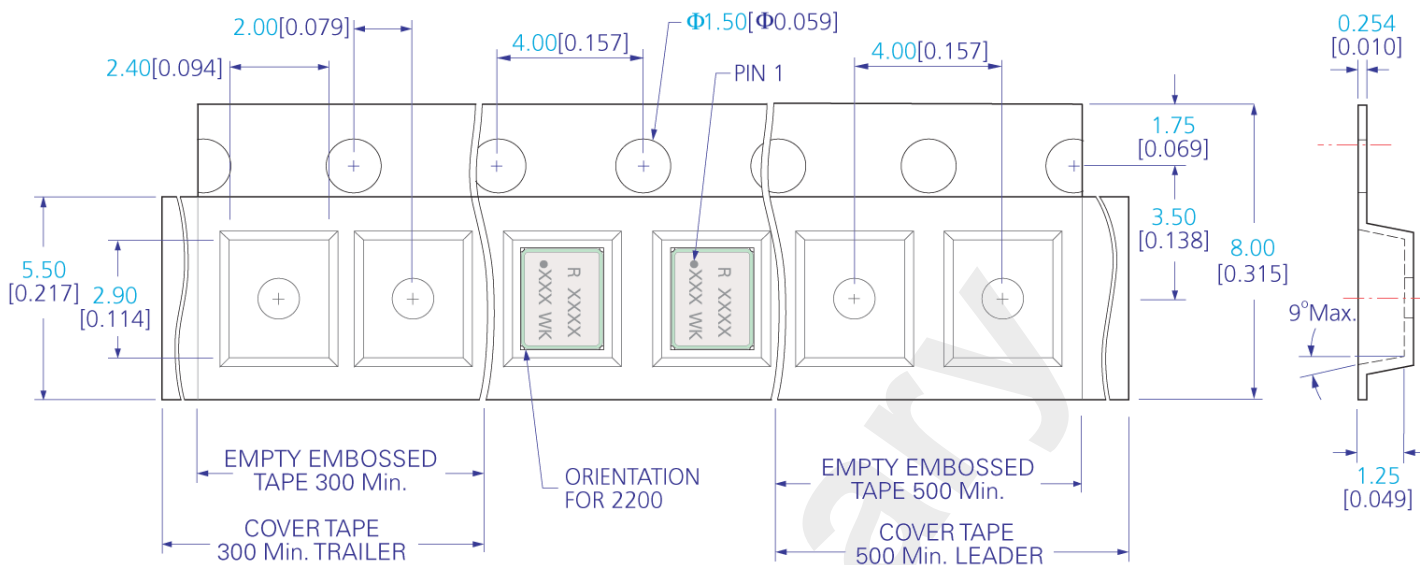

REEL DETAIL (SCALE 1 : 2.5)

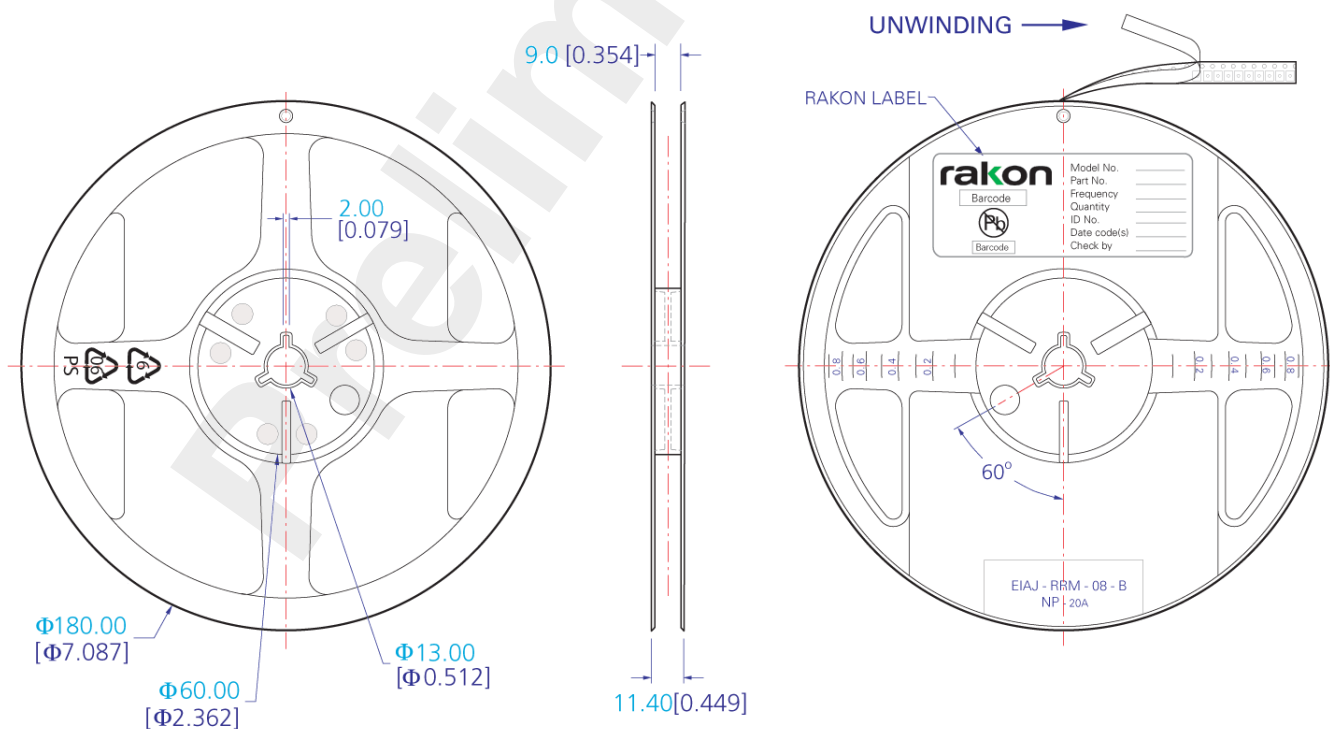

TITLE: 2200 SERIES TAPE & REEL

RELATED DRAWINGS:

FILENAME: CAT422

REVISION: C

DATE: 24-May-10

SCALE: See above

Millimetres [inch]

Tolerance:

XX = ±0.5

X.X = ±0.2

X.XX = ±0.10

X.XXX = ±0.05

X° = ±1.0°

Hole = ±0.10

rakon

©2009 Rakon Limited

Drawing Name: Pb-Free Reflow

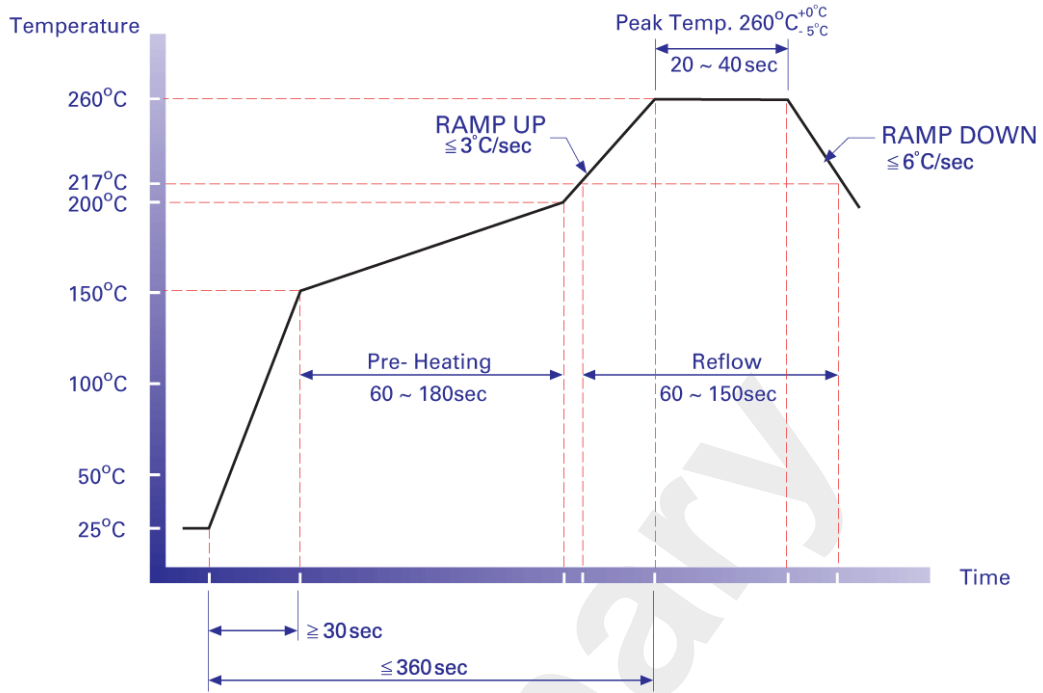

NOTE:

The product has been tested to withstand the Reflow Profile shown. The Reflow Profile used to solder Rakon products is determined by the solder paste manufacturer's specification. It is recommended that the Reflow Profile used does not exceed the one shown above.

TITLE: Pb-FREE REFLOW

RELATED DRAWINGS:

FILENAME: CAT541

REVISION: B

DATE: 07-Apr-10

SCALE: NTS

Millimetres [inch]

rakon

©2009 Rakon Limited

Specification History

Current Version : 1.01

Version	User	Change	Note
---------	------	--------	------

Preliminary