

SMD Temperature Compensated Crystal Oscillators

Low cost SMD TCXO with voltage control option, using an analogue IC for compensation. Frequencies ranging from 10MHz to 40MHz.

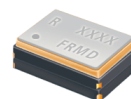

Product description

The IT3200C with voltage control option, employs an analogue IC for the oscillator and temperature compensation. The RSX-8 crystal is surface mounted on top of the ceramic IC carrier. The segregation of the crystal from the oscillator further improves the reliability of the product.

Applications

- Handset
- GPS
- Other
- WiFi
- WiMAX/WLAN

Features

Specifications

1.0 SPECIFICATION REFERENCES

Line	Parameter	Description
1.1	Model description	IT3200C / IVT3200C
1.2	RoHS Compliant	Yes

2.0 FREQUENCY CHARACTERISTICS

Line	Parameter	Test Condition	Value	Unit
2.1	Frequency	Frequency range available	10 to 40	MHz
2.2	Nominal frequency tolerance	Frequency at 25°C, sixty minutes after reflow	±2 max	ppm
2.3	Frequency stability over temperature	Referenced to the midpoint between minimum and maximum frequency value over the specified temperature range. Control voltage set to midpoint of control voltage (Note 1, 9)	±0.5 to 5	ppm
2.4	Temperature range	The operating temperature over which the frequency stability is measured (Note 2)	-40 to 85	°C
2.5	Frequency slope	Minimum of 1 frequency reading every 2°C, over the operating temperature range (note 3,9)	0.05 to 1	ppm/°C
2.6	Static temperature hysteresis	Frequency change after reciprocal temperature ramped over the operating range. Frequency measured before and after at 25°C	±0.6 max	ppm
2.7	Supply voltage stability	Supply voltage varied ±5% at 25°C (Note 3)	±0.1 max	ppm
2.8	Load sensitivity	±10% load change	±0.2 max	ppm
2.9	Long term stability	Frequency drift over 1 year (Note 3)	±2 max	ppm

3.0 POWER SUPPLY

Line	Parameter	Test Condition	Value	Unit
3.1	Supply voltage	Nominal supply voltage range (Note 4)	2.4 to 3.7	V
3.2	Current	At maximum supply voltage (Note 5)	2 max	mA

4.0 CONTROL VOLTAGE (VCO) - OPTIONAL

Line	Parameter	Test Condition	Value	Unit
4.1	Control voltage range	The nominal control voltage vaule is midway between the minimum and maximum (Note 8)	0.5 to 2.8	V
4.2	Frequency tuning linearity	Frequency shift from min to max control voltages (Note 6)	6 to 50	ppm
4.3	Port input impedance	Measured between Control voltage and GND pin	500 min	kOhm
4.4	Linearity	Deviation from straight line curve fit	20 max	%

5.0 OSCILLATOR OUTPUT

Line	Parameter	Test Condition	Value	Unit
5.1	Output waveform	DC coupled clipped sine-wave (Note 7)		
5.2	Output voltage level	At minimum supply voltage	0.8 min	V
5.3	Output load resistance	Refer test circuit	9 to 11	kOhm
5.4	Output load capacitance	Refer test circuit	9 to 11	pF

6.0 SSB PHASE NOISE

Line	Parameter	Test Condition	Value	Unit
6.1	SSB phase noise power density at 1Hz offset	Typical value for a 16.369 MHz oscillator at 25°C	-60	dBc/Hz
6.2	SSB phase noise power density at 10Hz offset	Typical value for a 16.369 MHz oscillator at 25°C	-89	dBc/Hz
6.3	SSB phase noise power density at 100Hz offset	Typical value for a 16.369 MHz oscillator at 25°C	-113	dBc/Hz
6.4	SSB phase noise power density at 1KHz offset	Typical value for a 16.369 MHz oscillator at 25°C	-132	dBc/Hz
6.5	SSB phase noise power density at 10KHz offset	Typical value for a 16.369 MHz oscillator at 25°C	-145	dBc/Hz

7.0 ENVIRONMENTAL

Line	Parameter	Description
7.1	Shock	Half sine-wave acceleration of 100G peak amplitude for 11ms duration, 3 cycles each plane
7.2	Humidity	After 48 hours at -85°C±2°C 85% relative humidity non-condensing
7.3	Thermal shcok	Exposed at -40°C for 30 minutes then to 85°C for 30 minutes constantly for a period of 5 days.
7.4	Storage temperature	-40°C to 85°C

8.0 MARKING

Line	Parameter	Description
8.1	Type	Engraved
8.2	Line 1	Rakon Logo and the last four characters of the Internal Part Number
8.3	Line 2	Pin 1 mark and Date Code

9.0 MANUFACTURING INFORMATION

Line	Parameter	Description
9.1	Washing	Able to withstand aqueous washing process
9.2	Reflow	Solder reflow processes as per profile attached
9.3	Packaging description	Tape and reel. Standard packing quantity is 3000 units per reel

10.0 SPECIFICATION NOTES

Line	Parameter	Description
10.1	Note 1	A maximum frequency stability over the temperature is required to be specified. Values between ± 0.3 and ± 5.0 ppm are available. Standard options are ± 0.5 ppm, ± 1.0 ppm, ± 1.5 ppm and ± 2.5 ppm
10.2	Note 2	The operating temperature range needs to be specified. The extremes for this model are -40 to 85 °C
10.3	Note 3	The maximum value is the specification. A minimum value, if present, indicates the best specification available
10.4	Note 4	The unit will operate on any voltage between minimum and maximum values
10.5	Note 5	Specified for the load stated in 5.3 and 5.4 at 25 °C
10.6	Note 6	The maximum frequency tuning range depends on the design frequency and the trimming sensitivity of the crystal. Linearity performance degrades if maximum frequency tuning setting is selected
10.7	Note 7	External AC-Coupling capacitor required. 1nF or greater recommended
10.8	Note 8	Voltage control cannot exceed Vcc -0.2V or below GND +0.2V
10.9	Note 9	parts should be shielded from drafts causing unexpected thermal gradients. Temperature changes due to ambient air currents can lead to short term frequency drift

Drawing Name: I(V)T3200C Model Drawing

MODEL DRAWING

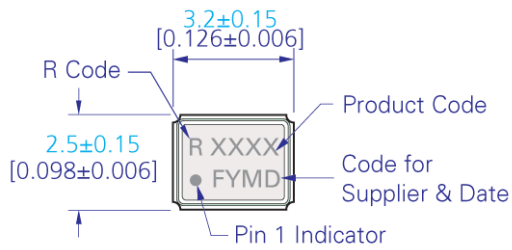

TOP VIEW



SIDE VIEW



END VIEW

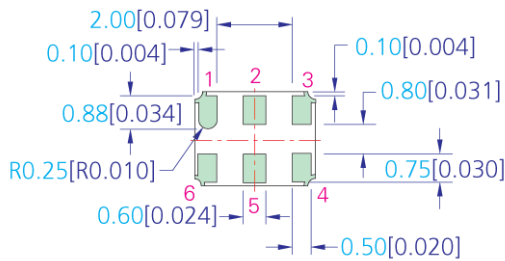

BOTTOM VIEW

PIN CONNECTIONS

Pin	IT	IVT
1	GND RECOMMENDED	VCO
2	NC	NC
3	GND	GND
4	OUTPUT	OUTPUT
5	NC	NC
6	VCC	VCC

RECOMMENDED PAD LAYOUT - TOP VIEW

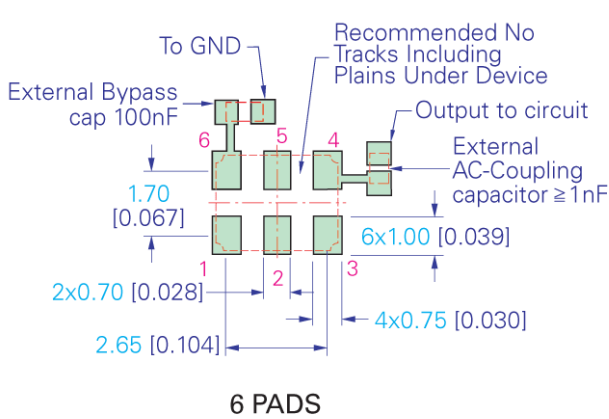

6 PADS

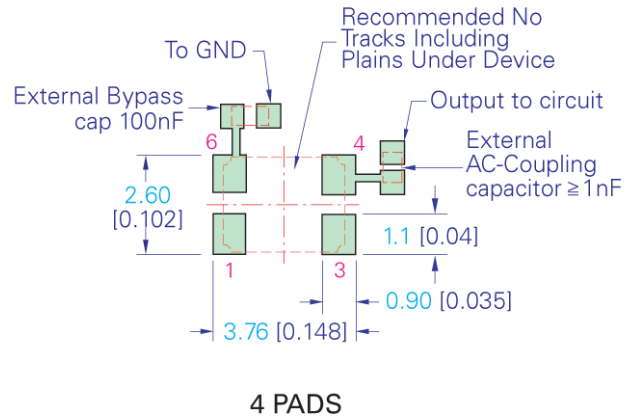

4 PADS

TITLE: I(V)T3200C MODEL

RELATED DRAWINGS:

FILENAME: CAT434

REVISION: E

DATE: 17-Feb-09

SCALE: 5 : 1

Millimetres [inch]

Tolerance:

XX = ±0.5

X.X = ±0.2

X.XX = ±0.10

X.XXX = ±0.05

X° = ±1.0°

Hole = ±0.10



©2009 Rakon Limited

Drawing Name: I(V)T3200 Series Test Circuit

IT TEST CIRCUIT :

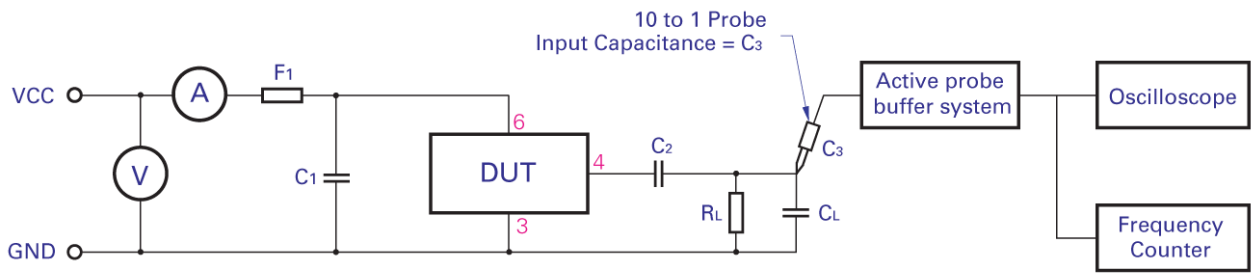

IVT TEST CIRCUIT :

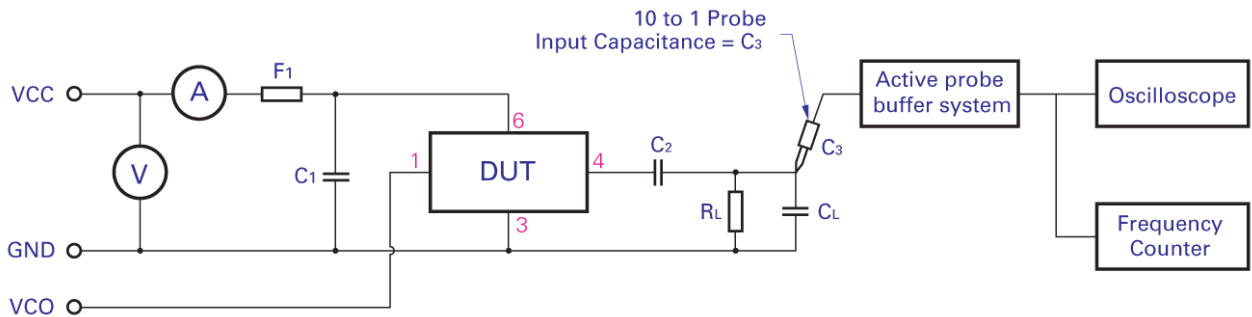

C_1 : 100nF

C_2 : ≥ 1 nF

R_L : 10K

$C_T = C_L + C_3$ (C_3 - Oscilloscope probe capacitance)

C_T as stated in OSCILLATOR OUTPUT section

F_1 : A ferrite bead or a resistor between $22\Omega \sim 47\Omega$ recommended.

TITLE: I(V)T3200 SERIES TEST CIRCUIT

RELATED DRAWINGS:

FILENAME: CAT286

REVISION: F

DATE: 17-Feb-09

SCALE: NTS

Millimetres [inch]

rakon

©2009 Rakon Limited

Drawing Name: 3200 Series Tape & Reel

TAPE DETAIL (SCALE 5 : 1)

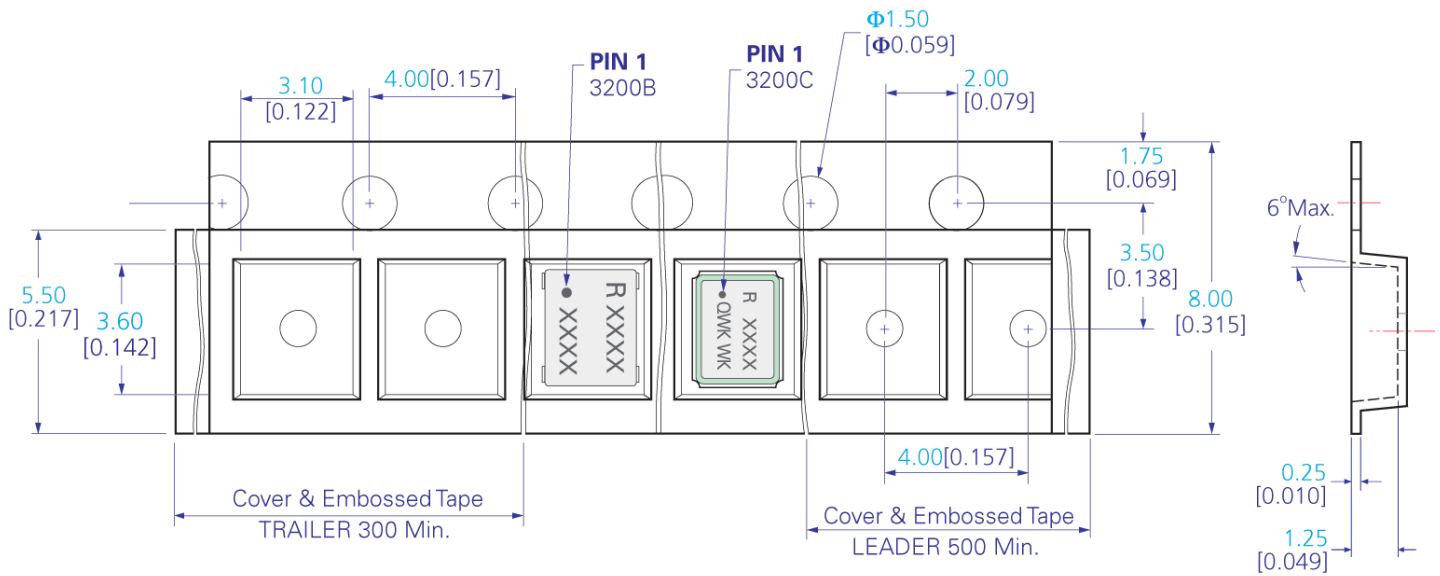

REEL DETAIL (SCALE 1 : 2.5)

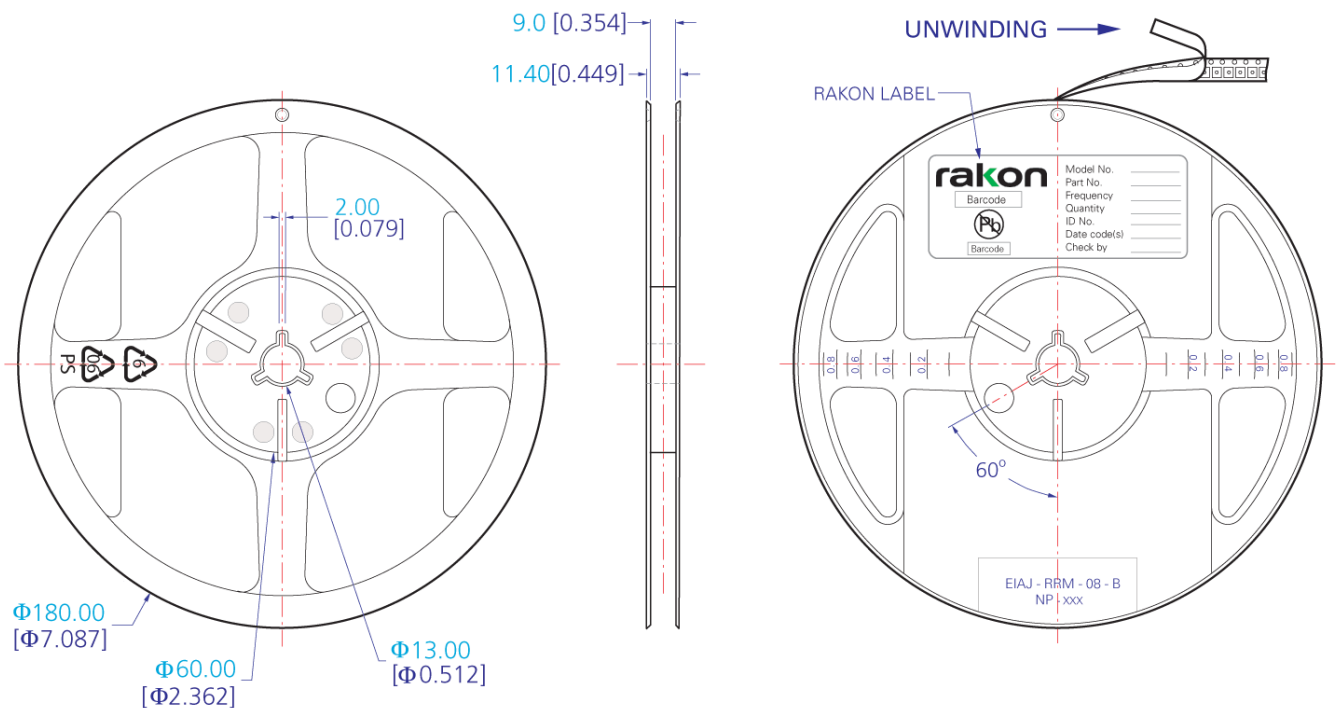

NOTE: STANDARD PACKING QUANTITY IS 3000 UNITS PER REEL

TITLE: 3200 SERIES TAPE & REEL

RELATED DRAWINGS:

FILENAME: CAT300

REVISION: G

DATE: 07-Jul-10

SCALE: See Above

Millimetres [inch]

Tolerance:

XX = ±0.5

X.X = ±0.2

X.XX = ±0.10

X.XXX = ±0.05

X° = ±1.0°

Hole = ±0.10

rakon

©2009 Rakon Limited

Drawing Name: Pb-Free Reflow

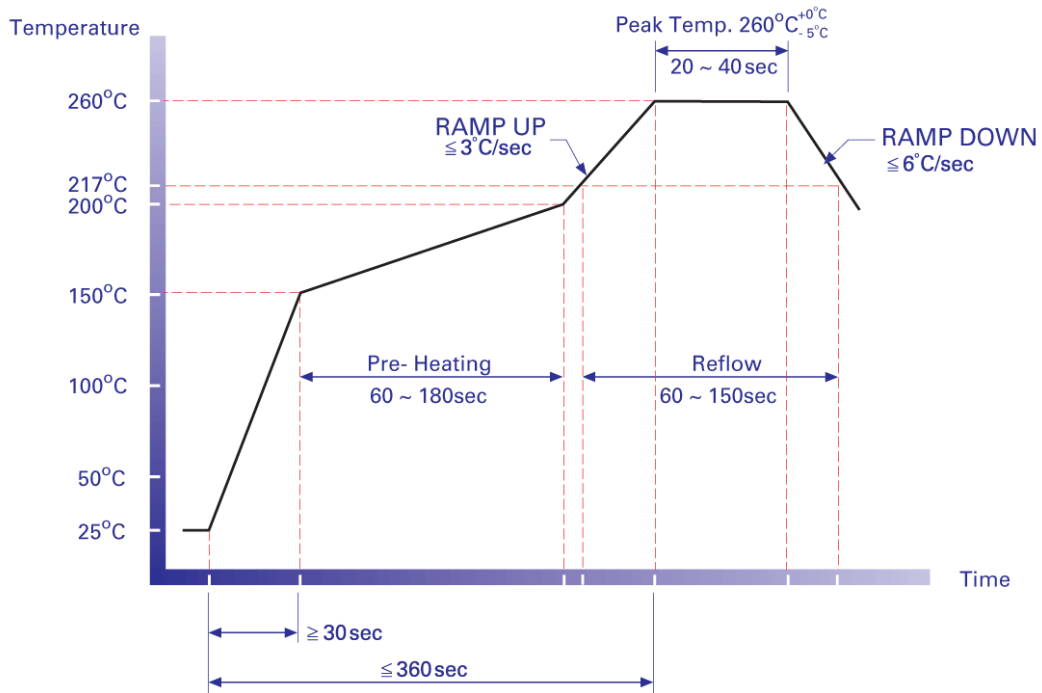

NOTE:

The product has been tested to withstand the Reflow Profile shown. The Reflow Profile used to solder Rakon products is determined by the solder paste manufacturer's specification. It is recommended that the Reflow Profile used does not exceed the one shown above.

TITLE: Pb-FREE REFLOW

RELATED DRAWINGS:

FILENAME: CAT541

REVISION: B

DATE: 07-Apr-10

SCALE: NTS

Millimetres [inch]



©2009 Rakon Limited

Specification History

Current Version : 1.01

Version	User	Change	Note
---------	------	--------	------