

# IT5300B



## SMD Controlled Temperature Compensated Crystal Oscillators

High stability SMD TCXO with voltage control option using an analogue IC for compensation. Frequencies ranging from 12MHz to 36MHz.

### Product description

The I(V)T5300B offers voltage control option and employs an analogue IC for the oscillator and temperature compensation. 5mm x 3.2mm x 1.5mm in size. The RSX-5 crystal is surface mounted on top of the ceramic IC carrier. The segregation of the crystal from the oscillator further improves the reliability of the product.

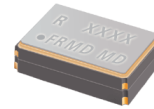

### Applications

- Handset
- GPS
- PDA
- PCMCIA CDPD cards
- LBS Handset
- Automotive
- Consumer Products
- PND
- WiFi
- Communications

### Features

- Excellent phase noise performance
- Frequency slope and perturbation specifications can be customized to the application requirement

### Specifications

#### 1.0 SPECIFICATION REFERENCES

Line	Parameter	Description
1.1	Model description	IT5300B / IVT5300B
1.2	RoHS compliant	Yes

#### 2.0 FREQUENCY CHARACTERISTICS

Line	Parameter	Test Condition	Value	Unit
2.1	Frequency range	Frequency range available	12 to 36	MHz
2.2	Frequency calibration	Offset from nominal frequency measured at 25°C ±2°C, sixty minutes after reflow	±1 max	ppm
2.3	Reflow shift	Two consecutive reflows as per attached profile after 1 hour relaxation at 25°C	±1 max	ppm
2.4	Frequency stability over temperature	Referenced to the midpoint between minimum and maximum frequency value over the specified temperature range. Control voltage held at 1.5V (Note 1)	±0.5 to 10	ppm
2.5	Temperature range	The operating temperature range over which the frequency stability is measured (Note 2)	-30 to 85	°C
2.6	Frequency slope	Minimum of 1 frequency reading every 2°C over operating temperature range (Note 3)	1 max	ppm/°C
2.7	Static temperature hysteresis	Frequency change after reciprocal temperature ramped over the operating range. Frequency measured before and after at 25°C.	0.6 max	ppm
2.8	Supply voltage stability	Supply voltage varied ±5% at 25°C (Note 3)	±0.1 max	ppm
2.9	Load sensitivity	±10% load change	±0.2 max	ppm
2.10	Long term stability	Frequency drift over 1 year (Note 3)	±1 max	ppm

**3.0 POWER SUPPLY**

Line	Parameter	Test Condition	Value	Unit
3.1	Supply voltage	Nominal supply voltage range (Note 4)	2.5 to 5.5	V
3.2	Current	At maximum supply voltage (Note 5)	2 max	mA

**4.0 CONTROL VOLTAGE (VCO) OPTION**

Line	Parameter	Test Condition	Value	Unit
4.1	Control voltage range	The nominal control voltage value is midway between the minimum and maximum	0.5 to 2.5	V
4.2	Frequency tuning	Frequency shift from min to max control voltages (Note 6)	6 to 30	ppm
4.3	Port input impedance	Measured between Control Voltage and GND pin	500	k $\Omega$

**5.0 OSCILLATOR OUTPUT**

Line	Parameter	Test Condition	Value	Unit
5.1	Output waveform	DC coupled clipped sinewave (Note 7)		
5.2	Output voltage level	At minimum supply voltage	0.8 min	V
5.3	Output load resistance	Nominal load of 10k $\Omega$	9 to 11	k $\Omega$
5.4	Output load capacitance	Nominal load of 10pF	9 to 11	pF

**6.0 SSB PHASE NOISE**

Line	Parameter	Test Condition	Value	Unit
6.1	SSB phase noise power density at 1Hz offset	Typical value for a 16.8MHz oscillator at 25°C	-60	dBc/Hz
6.2	SSB phase noise power density at 10Hz offset	Typical value for a 16.8MHz oscillator at 25°C	-89	dBc/Hz
6.3	SSB phase noise power density at 100Hz offset	Typical value for a 16.8MHz oscillator at 25°C	-116	dBc/Hz
6.4	SSB phase noise power density at 1KHz offset	Typical value for a 16.8MHz oscillator at 25°C	-135	dBc/Hz
6.5	SSB phase noise power density at 10KHz offset	Typical value for a 16.8MHz oscillator at 25°C	-151	dBc/Hz

**7.0 ENVIRONMENTAL**

Line	Parameter	Description
7.1	Shock	Half sinewave acceleration of 100G peak amplitude for 6ms duration, 3 cycles each plain
7.2	Humidity	After 48 hours at 85°C $\pm$ 2°C 85%relative humidity non-condensing
7.3	Thermal shock	Exposed at -40°C for 30 minutes then to 85°C for 30 minutes constantly for a period of 5 days
7.4	Storage temperature	-40 to 85°C
7.5	Vibration	10G RMS from 30 Hz random in each of the 3 axis for 4 hours, total 12 hours (Note 8)

**8.0 MARKING**

Line	Parameter	Description
8.1	Type	Engraved
8.2	Line 1	R and product code
8.3	Line 2	Pin 1 and date code

**9.0 MANUFACTURING INFORMATION**

Line	Parameter	Description
9.1	Reflow	Solder reflow processes
9.2	Packaging description	Tape and reel. Standard packing quantity is 2000 units per reel

**10.0 SPECIFICATION NOTES**

Line	Parameter	Description
10.1	Note 1	A maximum frequency stability over the temperature is required to be specified. Values between $\pm 0.3$ and $\pm 10.0$ ppm are available. Standard options are $\pm 0.5$ ppm, $\pm 1.0$ ppm, $\pm 1.5$ ppm and $\pm 2.5$ ppm
10.2	Note 2	The operating temperature range needs to be specified. The extremes for this model are $-40^{\circ}$ C and $85^{\circ}$ C
10.3	Note 3	The maximum value is the specification. A minimum value, if present indicates the best specification available
10.4	Note 4	The unit will operate on any voltage between minimum and maximum values
10.5	Note 5	Specified for load stated in 5.3 and 5.4 at $25^{\circ}$ C
10.6	Note 6	The maximum frequency tuning range depends on the design frequency and the trimming sensitivity of the crystal. Linearity performance degrades if maximum frequency tuning setting is selected
10.7	Note 7	External AC-Coupling capacitor required. 1nF or greater recommended
10.8	Note 8	Frequency shift $\leq 1$ ppm after environmental conditions

Drawing Name: I(V)T5300B Model Drawing

**MODEL DRAWING**

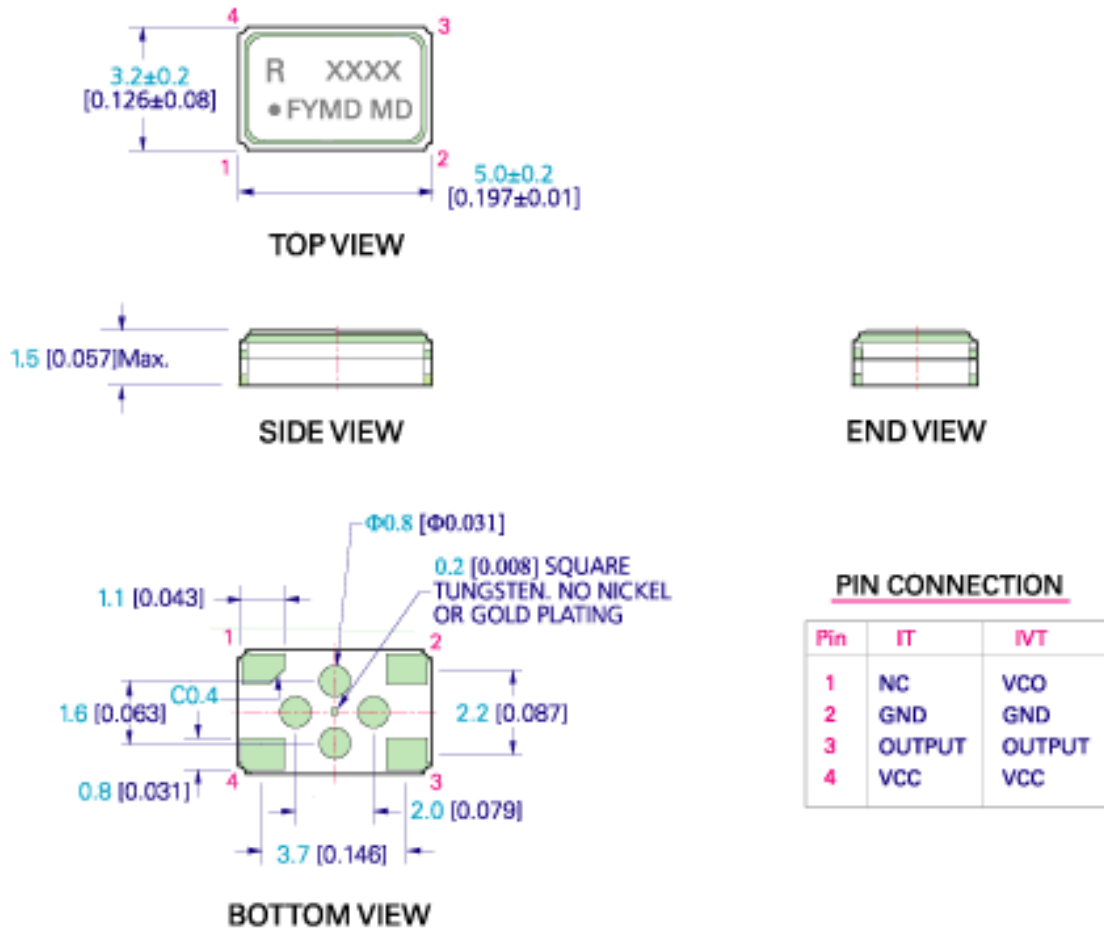

**RECOMMENDED PAD LAYOUT - TOP VIEW**

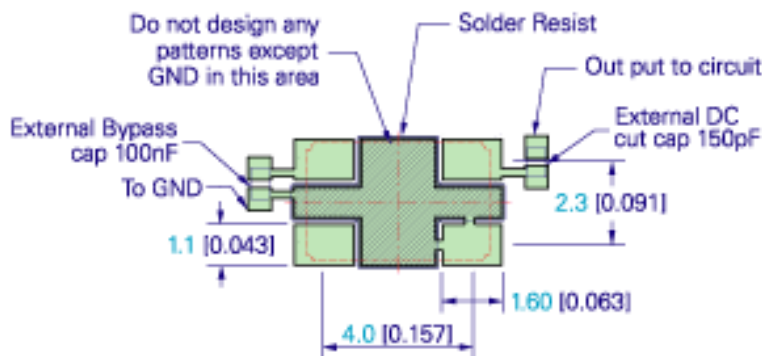

TITLE: I(V)T5300B MODEL(Wire Bond)

RELATED DRAWINGS:

FILENAME: CAT249

REVISION: D

DATE: 17-Apr-09

SCALE: 5 : 1

Millimetres [inch]

Tolerance:

XX = ±0.5

X.X = ±0.2

X.XX = ±0.10

X.XXX = ±0.05

X<sup>0</sup> = ±1.0°

Hole = ±0.10

**rakon**

©2009 Rakon Limited

**Drawing Name: I(V)T5300, 7500 Series Lid Marking**

Marking:

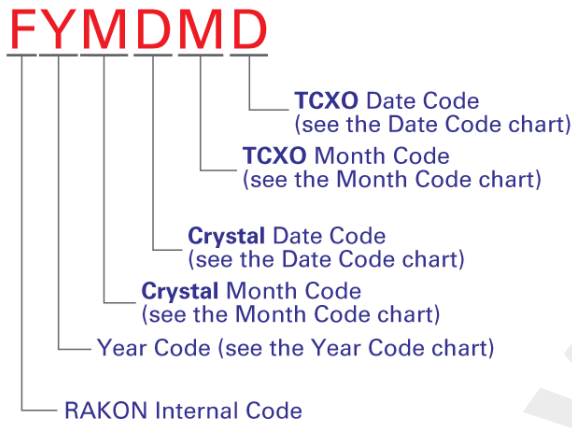
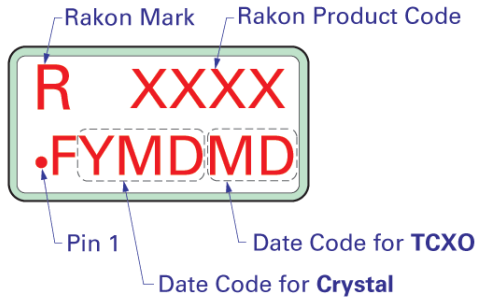

Example:

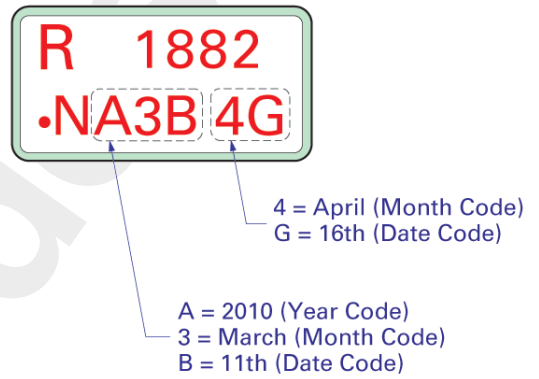

Y - Year Code

M - Month Code

D - Date Code

Code	Year	Code	Year	Code	Year
0	2000	A	2010	N	2023
1	2001	B	2011	O	2024
2	2002	C	2012	P	2025
3	2003	D	2013	Q	2026
4	2004	E	2014	R	2027
5	2005	F	2015	S	2028
6	2006	G	2016	T	2029
7	2007	H	2017	U	2030
8	2008	I	2018	V	2031
9	2009	J	2019	W	2032
		K	2020	X	2033
		L	2021	Y	2034
		M	2022	Z	2035

Code	Month
1	January
2	February
3	March
4	April
5	May
6	June
7	July
8	August
9	September
A	October
B	November
C	December

Code	Date	Code	Date	Code	Date
1	1st	E	14th	R	27th
2	2nd	F	15th	S	28th
3	3rd	G	16th	T	29th
4	4th	H	17th	U	30th
5	5th	I	18th	V	31th
6	6th	J	19th		
7	7th	K	20th		
8	8th	L	21st		
9	9th	M	22nd		
A	10th	N	23rd		
B	11th	O	24th		
C	12th	P	25th		
D	13th	Q	26th		

Note: 1 MUST BE DIFFERENT TO I.

TITLE: I(V)T5300, 7500 SERIES LID MARKING

FILENAME: CAT188

RELATED DRAWINGS:

REVISION: C

DATE: 02-Jul-10

SCALE: NTS

Millimeters [inch]



©2009 Rakon Limited

Drawing Name: I(V)T5300 Series Test Circuit

IT TEST CIRCUIT :

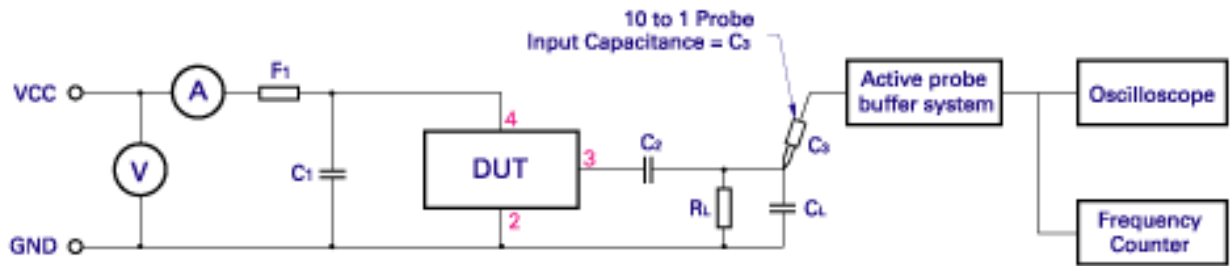

IVT TEST CIRCUIT :

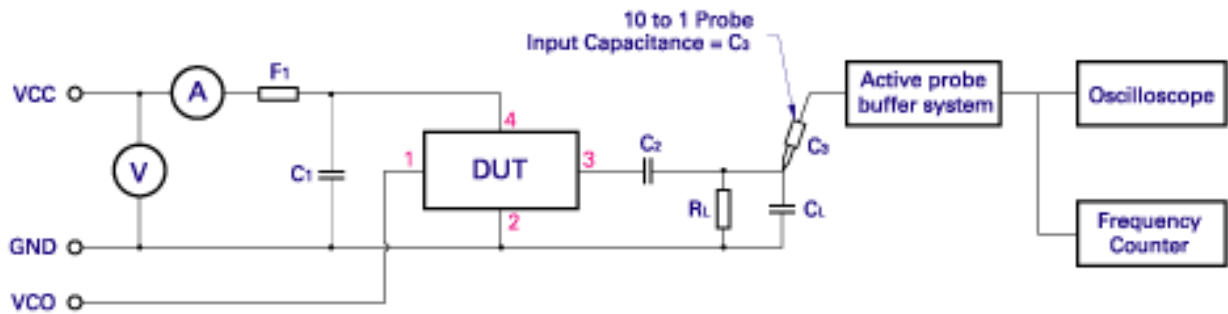

C1: 100nF

C2:  $\geq 1$ nF

RL: 10K

$C_T = C_L + C_s$  ( $C_s$  - Oscilloscope probe capacitance)

$C_T$  as stated in OSCILLATOR OUTPUT section

F1: A ferrite bead or a resistor between 22 $\Omega$  - 47 $\Omega$  recommended.

TITLE: I(V)T5300 SERIES TEST CIRCUIT

RELATED DRAWINGS:

FILENAME: CAT287

REVISION: F

DATE: 17-Feb-09

SCALE: NTS

Millimetres [inch]

**rakon**

©2009 Rakon Limited

Not for

**Drawing Name: I(V)T5300 Series Tape & Reel**

TAPE DETAIL (SCALE 2 : 1)

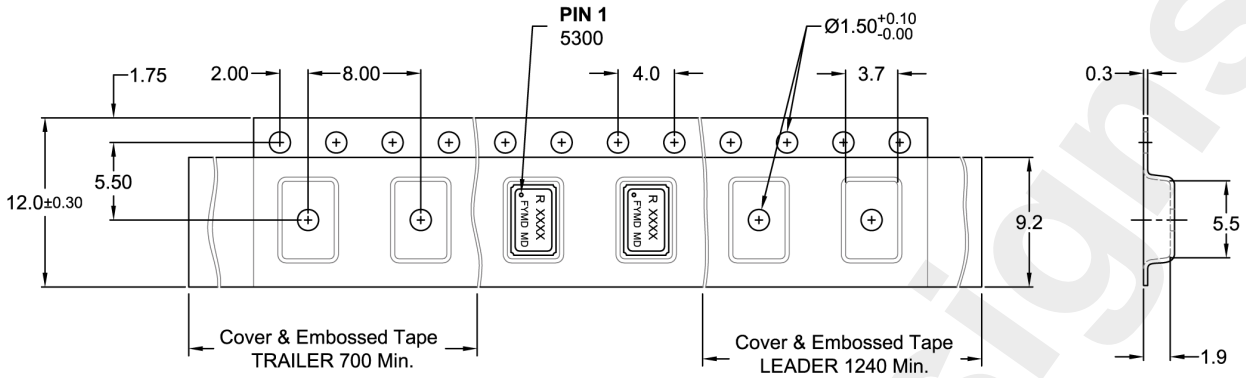

REEL DETAIL (SCALE 1 : 2.5)

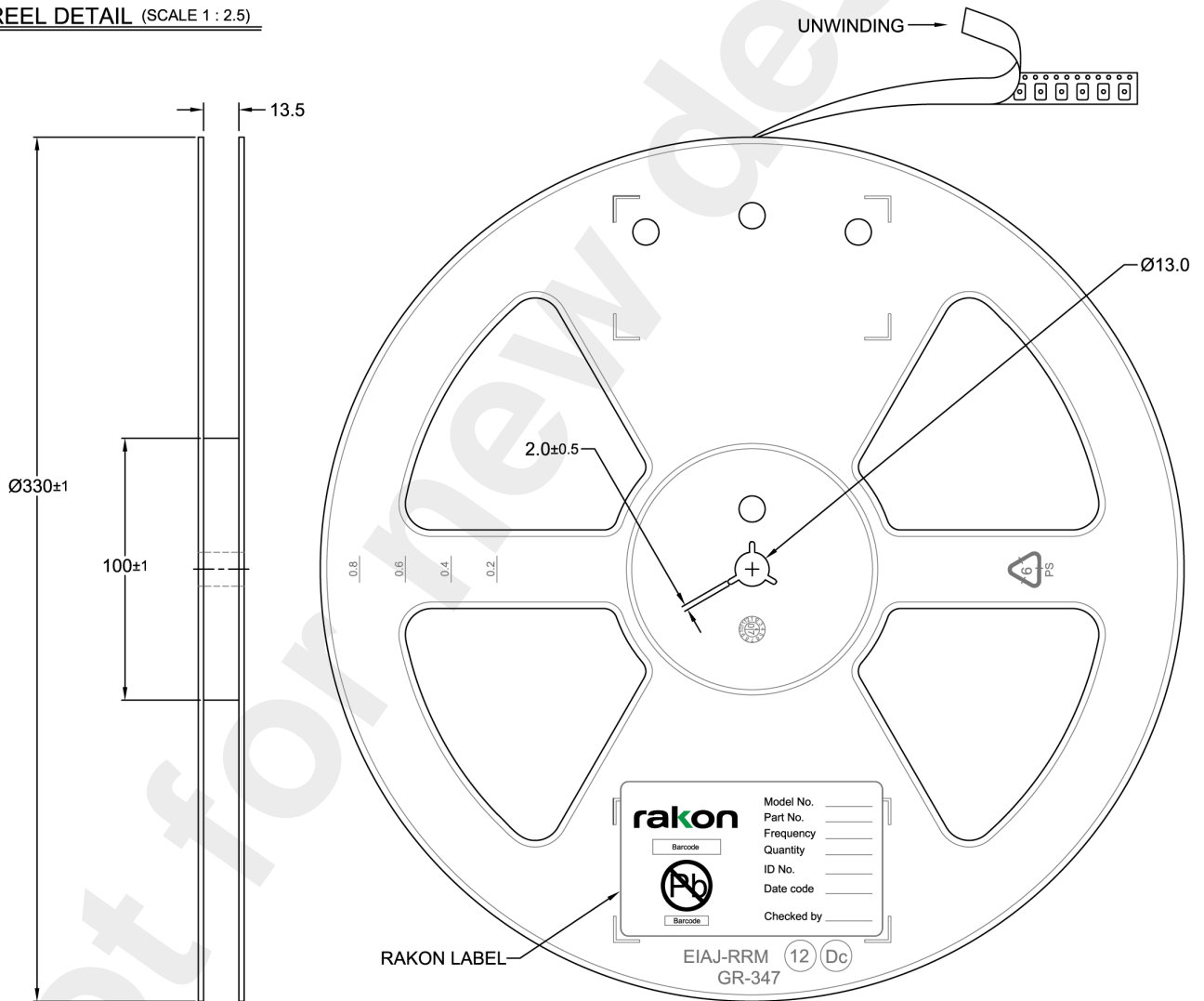

TITLE: 5032 SERIES TAPE REEL

RELATED DRAWINGS:

FILENAME: CAT449

REVISION: F

DATE: 22-Aug-11

SCALE: 2 : 1

Millimetres

TOLERANCES:

XX =  
 X.X = ±0.1  
 X.XX = ±0.05  
 X.XXX =  
 X° =  
 Hole =



© 2009 Rakon Limited

**Drawing Name: Pb-Free Reflow**

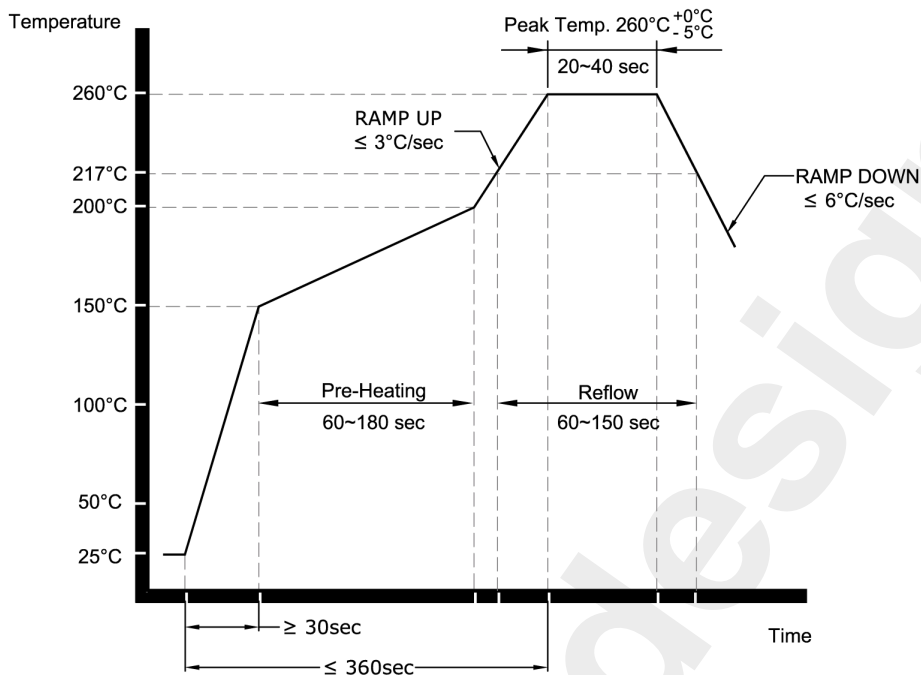

**NOTE:**

The product has been tested to withstand the Reflow Profile shown. The Reflow Profile used to solder Rakon products is determined by the solder paste Manufacturer's specification. It is recommended that the Reflow Profile used does not exceed the one shown above.

TITLE: Pb-FREE REFLOW

RELATED DRAWINGS:

FILENAME: CAT541

REVISION: B

DATE: 05-Sep-11

SCALE: NTS

Millimetres



© 2009 Rakon Limited

## Specification History

Current Version : 1.01

Version	User	Change	Note	Date
---------	------	--------	------	------

Not for new designs