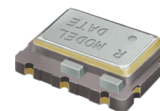

IT7500B

SMD Temperature Compensated Crystal Oscillator with voltage control option.

Miniature 7 mm x 5 mm, low cost SMD TCXO using an analogue IC for compensation. Frequencies ranging from 10 MHz to 36 MHz.

Product description

The I(V)T7500B employs an analogue IC for the oscillator and the temperature compensation giving excellent temperature stability performance.

Applications

- Other
- Consumer Products
- Two-way Pagers
- PCMCIA CDPD cards
- WiMAX/WLAN

Features

- Frequency slope and perturbation specifications can be customized to the application requirement
- Internal power regulation. Unit can operate on any supply voltage between 2.5 and 5.5 Volts.
- Standard temperature stability as low as ± 1.0 ppm over wide temperature ranges.

Specifications
1.0 SPECIFICATION REFERENCES

Line	Parameter	Description
1.1	Model Description	I(V)T7500B
1.2	RoHS Compliant	Yes
1.3	Reference Number	

2.0 FREQUENCY CHARACTERISTICS

Line	Parameter	Test Condition	Value	Unit
2.1	Frequency range	Frequency range available	10 to 36	MHz
2.2	Nominal frequency tolerance	Frequency at 23°C ± 2 °C sixty minutes after reflow.	± 2 max	ppm
2.3	Frequency stability over temperature	Referenced to the mid point between minimum and maximum frequency value over the specified temperature range (Note 2)	± 0.5 to 10	ppm
2.4	Temperature range	The operating temperature range over which the frequency stability is measured (Note 3).	-30 to 85	°C
2.5	Frequency slope of perturbations	Minimum of 1 frequency reading every 2°C over operating temperature range (Note 1).	1 max	ppm/°C
2.6	Static temperature hysteresis	Frequency change after the reciprocal temperature ramped over the operating range. Frequency measured before and after 25°C.	± 0.6 max	ppm
2.7	Supply voltage stability	Supply voltage varied $\pm 5\%$ at 25°C (Note 1).	± 0.1 max	ppm
2.8	Load sensitivity	$\pm 10\%$ load change.	± 0.2 max	ppm
2.9	Root Allan Variance	1 second Tau. (Note 1).	0.2 to 1	ppb
2.10	Long term stability	Frequency drift over 1 year (Note 1).	± 1 max	ppm
2.11	G Sensitivity	Gamma vector of all three axes from 30 Hz to 1500 Hz, typical values (Note 1).	0.5 to 2	ppb/G

3.0 POWER SUPPLY

Line	Parameter	Test Condition	Value	Unit
3.1	Supply Voltage	Nominal supply voltage range (Note 4)	2.5 to 5.5	V
3.2	Current	At minimum supply voltage (Note 5).	2 max	mA

4.0 OSCILLATOR OUTPUT

Line	Parameter	Test Condition	Value	Unit
4.1	Output waveform	Clipped sine-wave		
4.2	Output voltage level	At minimum supply voltage.	0.8 min	V
4.3	Output load resistance	Operating range.	9 to 11	kOhm
4.4	Output load capacitance	Operating range.	9 to 11	pF

5.0 CONTROL VOLTAGE (VCO) - Optional

Line	Parameter	Test Condition	Value	Unit
5.1	Control voltage range	The nominal control voltage value is midway between the minimum and maximum.	0.5 to 2.5	V
5.2	Frequency tuning	Frequency shift from minimum to maximum control voltages (Note 6).	6 to 50	ppm
5.3	Frequency tuning linearity	Deviation from straight line curve (Note 1).	2 to 20	%
5.4	Port input impedance		500 min	kOhm

6.0 SSB PHASE NOISE

Line	Parameter	Test Condition	Value	Unit
6.1	SSB phase noise power density at 1Hz offset	Results based on 16.367 MHz oscillator at 25°C	-57	dBc/Hz
6.2	SSB phase noise power density at 10Hz offset	Results based on 16.367 MHz oscillator at 25°C	-86	dBc/Hz
6.3	SSB phase noise power density at 100Hz offset	Results based on 16.367 MHz oscillator at 25°C	-112	dBc/Hz
6.4	SSB phase noise power density at 1KHz offset	Results based on 16.367 MHz oscillator at 25°C	-132	dBc/Hz
6.5	SSB phase noise power density at 10KHz offset	Results based on 16.367 MHz oscillator at 25°C	-145	dBc/Hz

7.0 ENVIRONMENTAL

Line	Parameter	Description
7.1	Shock	Half sinewave acceleration of 100G peak amplitude for 6ms duration, 3 cycles for each plane
7.2	Random Vibration	10G RMS 30Hz to 1500Hz duration of 6 hours.
7.3	Humidity	After 48 hours at 85°C \pm 2°C 85% relative humidity non-condensing
7.4	Thermal shock test	Exposed at -40°C for 30 minutes then to 85°C for 30 minutes constantly for a period of 5 days
7.5	Storage temperature	-40 to 85°C

8.0 MARKING

Line	Parameter	Description
8.1	Type	Engraved
8.2	Line 1	Rakon Logo and the last four characters of the Internal Part Number
8.3	Line 2	Pin 1 mark and Date Code

9.0 MANUFACTURING INFORMATION

Line	Parameter	Description
9.1	Washing and reflow	Able to withstand aqueous washing process and normal solder reflow processes.
9.2	Packaging description	Tape and reel. Standard packing quantity is 2000 units per reel

10.0 SPECIFICATION NOTES

Line	Parameter	Description
10.1	Note 1	The maximum value is the specification. A minimum value, if present, indicates the tightest specification available.
10.2	Note 2	A maximum frequency stability over the temperature is required to be specified. For this model series, values between ± 1 ppm and ± 10 ppm are available. Standard options are ± 1 ppm, ± 1.5 ppm, ± 2 ppm and ± 2.5 ppm.
10.3	Note 3	The operating temperature range needs to be specified. The extremes for this model are -40 and $+85^{\circ}\text{C}$. If either or both ends of the operating temperature range are at these extremes, then the frequency stability options are limited to greater than ± 1.0 ppm.
10.4	Note 4	The unit will operate on any voltage between minimum and maximum values.
10.5	Note 5	Specified for load stated in 4.3 and 4.4 at 25°C .
10.6	Note 6	The minimum value is the specification. A maximum value, if present, indicates the widest tuning range available for this model (subject to other parameters).

Drawing Name: I(V)T7500B Model Drawing

MODEL DRAWING

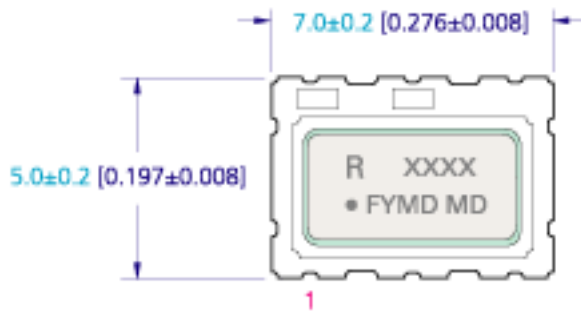

TOP VIEW



SIDE VIEW

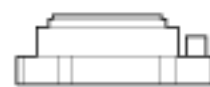

END VIEW

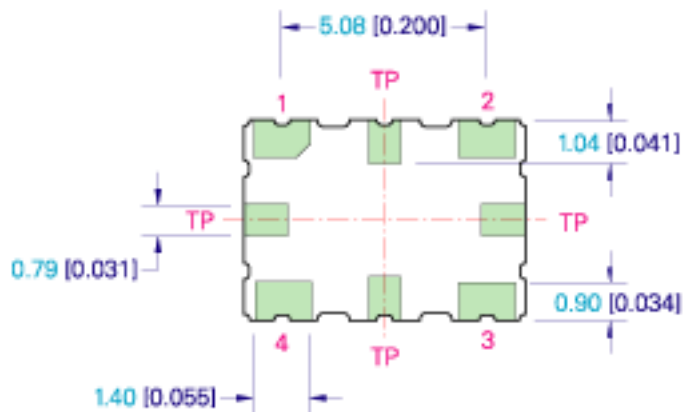

BOTTOM VIEW

PIN CONNECTIONS

Pin	IT	IVT
1	GND RECOMMENDED	VCO
2	GND	GND
3	OUTPUT	OUTPUT
4	VCC	VCC

RECOMMENDED PAD LAYOUT - TOP VIEW

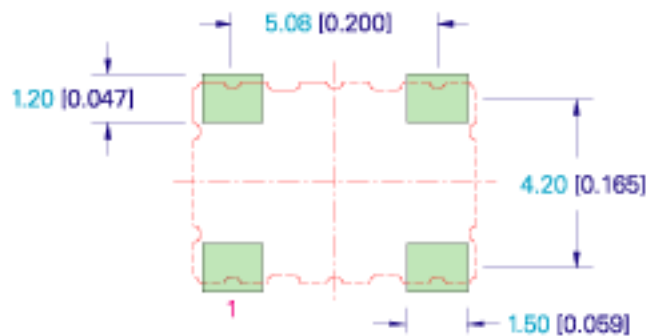

TITLE: I(V)T7500B MODEL

RELATED DRAWINGS:

FILENAME: CAT307

REVISION: C

DATE: 31-Jul-09

SCALE: 5 : 1

Millimetres [inch]

Tolerance:

XX = ±0.5

X.X = ±0.2

X.XX = ±0.10

X.XXX = ±0.05

X^o = ±1.0°

Hole = ±0.10



©2009 Rakon Limited

Drawing Name: I(V)T5300, 7500 Series Lid Marking

Marking:

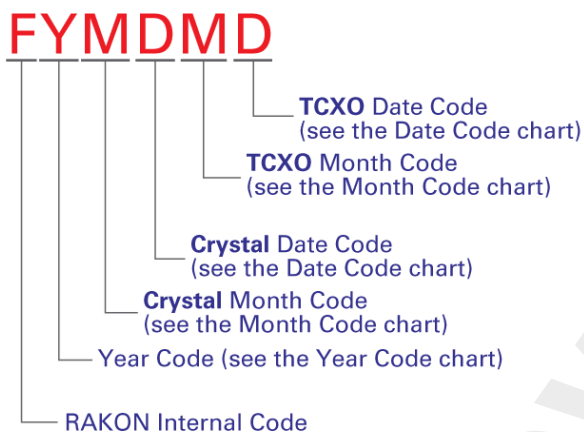
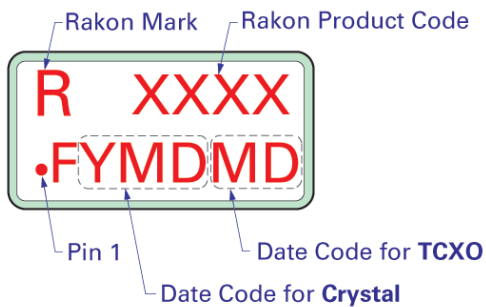

Example:

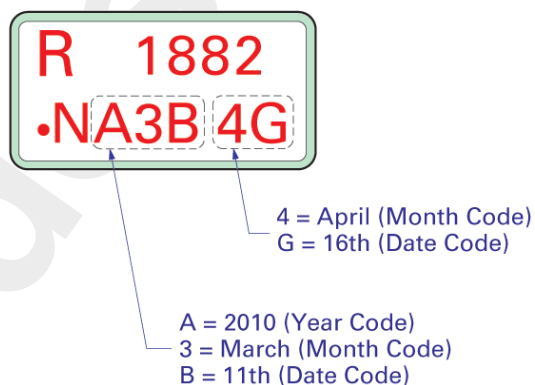

Y - Year Code

M - Month Code

D - Date Code

Code	Year	Code	Year	Code	Year
0	2000	A	2010	N	2023
1	2001	B	2011	O	2024
2	2002	C	2012	P	2025
3	2003	D	2013	Q	2026
4	2004	E	2014	R	2027
5	2005	F	2015	S	2028
6	2006	G	2016	T	2029
7	2007	H	2017	U	2030
8	2008	I	2018	V	2031
9	2009	J	2019	W	2032
		K	2020	X	2033
		L	2021	Y	2034
		M	2022	Z	2035

Code	Month
1	January
2	February
3	March
4	April
5	May
6	June
7	July
8	August
9	September
A	October
B	November
C	December

Code	Date	Code	Date	Code	Date
1	1st	E	14th	R	27th
2	2nd	F	15th	S	28th
3	3rd	G	16th	T	29th
4	4th	H	17th	U	30th
5	5th	I	18th	V	31th
6	6th	J	19th		
7	7th	K	20th		
8	8th	L	21st		
9	9th	M	22nd		
A	10th	N	23rd		
B	11th	O	24th		
C	12th	P	25th		
D	13th	Q	26th		

Note: 1 MUST BE DIFFERENT TO I.

TITLE: I(V)T5300, 7500 SERIES LID MARKING

FILENAME: CAT188

RELATED DRAWINGS:

REVISION: C

DATE: 02-Jul-10

SCALE: NTS

Millimeters [inch]



©2009 Rakon Limited

Drawing Name: I(V)T7500 Series Test Circuit

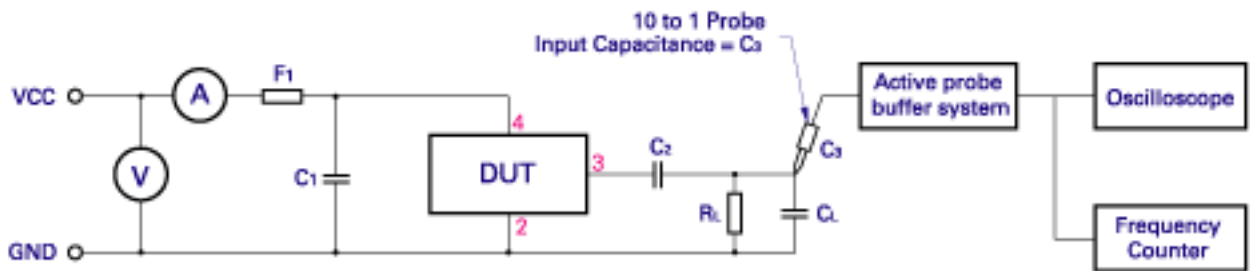
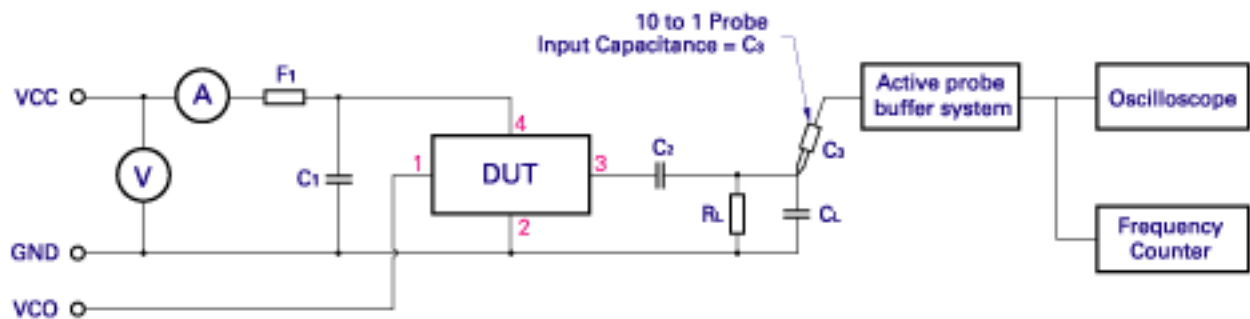
IT TEST CIRCUIT :IVT TEST CIRCUIT :

C_1 : 100nF

C_2 : ≥ 1 nF

R_L : 10K

$C_T = C_L + C_S$ (C_S - Oscilloscope probe capacitance)

C_T as stated in OSCILLATOR OUTPUT section

F_1 : A ferrite bead or a resistor between $22\Omega \sim 47\Omega$ recommended.

TITLE: I(V)T7500B SERIES TEST CIRCUIT

RELATED DRAWINGS:

FILENAME: CAT402

REVISION: B

DATE: 31-Jul-09

SCALE: NTS

Millimetres [inch]

rakon

©2009 Rakon Limited

Drawing Name: I(V)T7500 Series Tape & Reel

TAPE DETAIL (SCALE 2 : 1)

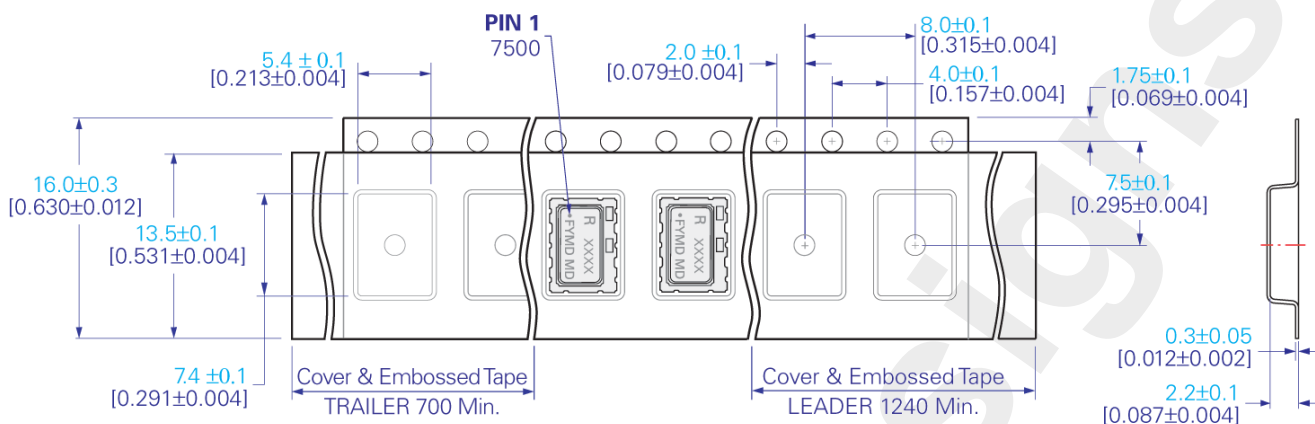

REEL DETAIL (SCALE 1 : 2.5)

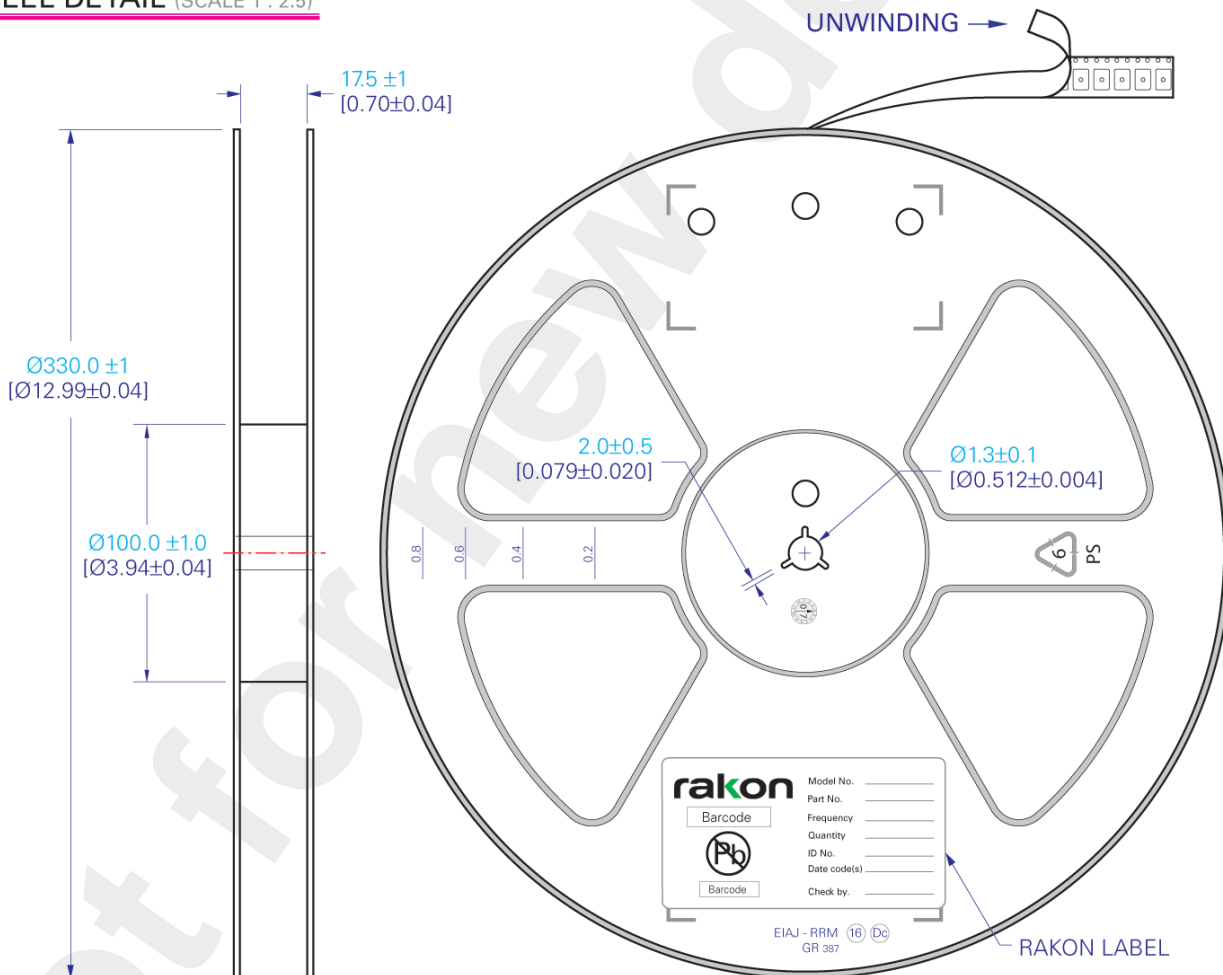

NOTE: STANDARD PACKING QUANTITY IS 2000 UNITS PER REEL

TITLE: I(V)T7500 TAPE & REEL

RELATED DRAWINGS:

FILENAME: CAT407

REVISION: E

DATE: 13-Jul-10

SCALE: See Above

Millimetres [inch]

Tolerance:

XX = ±0.5

X.X = ±0.2

X.XX = ±0.10

X.XXX = ±0.05

X° = ±1.0°

Hole = ±0.10



©2009 Rakon Limited

Drawing Name: Pb-Free Reflow

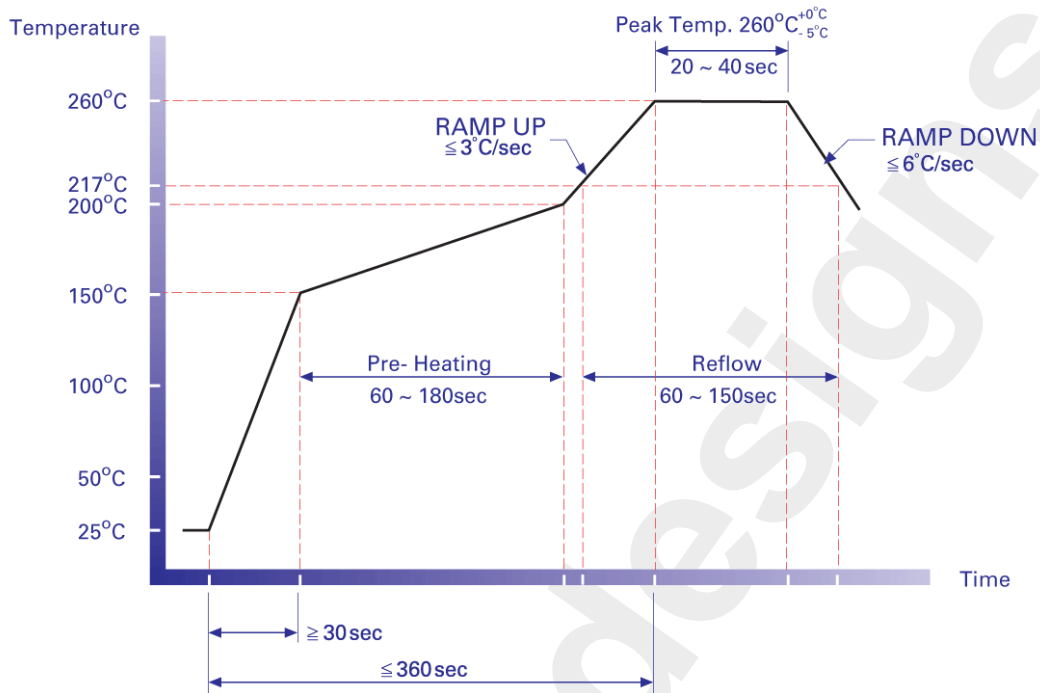

NOTE:

The product has been tested to withstand the Reflow Profile shown. The Reflow Profile used to solder Rakon products is determined by the solder paste manufacturer's specification. It is recommended that the Reflow Profile used does not exceed the one shown above.

TITLE: Pb-FREE REFLOW

RELATED DRAWINGS:

FILENAME: CAT541

REVISION: B

DATE: 07-Apr-10

SCALE: NTS

Millimetres [inch]



©2009 Rakon Limited

Specification History

Current Version : 1.01

Version	User	Change	Note
---------	------	--------	------

Not for new design