

# RFPT200



The CHARON is a SPI controlled high accuracy TCXO with embedded timer and alarm function.

The Charon is a high stability 7x5 SMD Digitally Controlled Temperature Controlled Crystal Oscillator (DCTCXO) designed and specified to bring together the highest stability TCXO performance with digital frequency control, separate low frequency output, timer and alarm functionality.

## Product description

Serial Peripheral Interface (SPI) controlled high accuracy TCXO with embedded timer and alarm function. Using Rakon's advanced Pluto™ analogue frequency compensation system, the DCTCXO achieves unrivalled frequency stability. A custom ASIC, Charon (Pluto's moon) has been designed to closely interface with the Pluto™ ASIC to provide the extra enhanced functionality in a miniature 7x5 SMD package. In addition to market leading stability the Charon device features integrated timing and control functions. A low frequency timing pulse is derived from a programmable division ratio of the high stability oscillator. This drives the onboard 32 bit timer, which coupled to a 32 bit programmable comparator and alarm circuitry, enables a system to enter a low power standby mode and be woken at a precise time in the future. All digital control is via a standard 4-wire SPI interface.



## Applications

- Military
- Other

## Features

- 32 bit timer
- Digital frequency adjustment
- Low frequency timing pulse

## Specifications

### 1.0 SPECIFICATION REFERENCES

Line	Parameter	Description
1.1	Model description	RFPT-200 'Charon'
1.2	RoHS compliant	Available on request
1.3	Package size available	7.0mm x 5.0mm

### 2.0 FREQUENCY CHARACTERISTICS

Line	Parameter	Test Condition	Value	Unit
2.1	Frequency range	Frequency range available depends on output type. Refer to note 1	3 to 40	MHz
2.2	Calibration tolerance at 25°C	At 25°C at mid-range of DAC, reference nominal frequency	±0.5 to 1	ppm
2.3	Temperature range	Reference (Fmax +Fmin)/2. Refer to note 2	-55 to 95	°C
2.4	Stability with temperature	Refer to note 2	±0.15 to 2	ppm
2.5	Stability vs. supply voltage changes	±5% variation in supply voltage	±0.05 to 0.2	ppm
2.6	Stability vs. load changes	±10% variation in load	±0.05 to 0.2	ppm
2.7	Drift due to reflow soldering	At 25°C, at mid-range of DAC, 24 Hrs after reflow	±0.5 to 1	ppm
2.8	Long term stability	At 25°C, first year	±0.5 to 2	ppm

### 3.0 POWER SUPPLY

Line	Parameter	Test Condition	Value	Unit
3.1	Supply voltage Vs	Normally specified as nominal (Vs) ±5%	2.5 to 5.5	V
3.2	Supply current	3.3V, load 10kΩ//10pF (min.@ 10MHz, max.@ 40MHz)	2 to 6	mA
3.3	Supply current	RF output disabled (min.@ 10MHz, max.@ 40MHz)	1.4 to 1.8	mA

**4.0 OSCILLATOR OUTPUT-HCMOS**

Line	Parameter	Test Condition	Value	Unit
4.1	Output waveform	HCMOS		
4.2	Output voltage level low		0.1 max	Vcc
4.3	Output voltage level high		0.9 min	Vcc
4.4	Rise and fall times	10% to 90% of Voh-Vol	4 to 8	ns
4.5	Duty cycle		45 to 55	%
4.6	Load	Normally specified at CL±10%, nominal value 10pF	10 to 50	pF

**5.0 OSCILLATOR OUTPUT- CLIPPED SINEWAVE**

Line	Parameter	Test Condition	Value	Unit
5.1	Output waveform	Clipped sinewave (DC coupled)		
5.2	Output voltage level	Peak to peak voltage measured at minimum supply voltage	0.8	Vpp
5.3	Output load resistance	Operating range	9 to 11	k
5.4	Output load capacitance	Operating range	9 to 11	pF

**6.0 TRISTATE CONTROL**

Line	Parameter	Test Condition	Value	Unit
6.1	Output enabled		0.6 min	Vcc
6.2	Output tristate mode		0.2 max	Vcc
6.3	Tri-state control	Note in tri-state mode, the RF output stage is disabled but the oscillator, compensation circuit and digital section are still active. An RF enable signal to stable frequency operation is therefore very rapid		

**7.0 PHASE NOISE**

Line	Parameter	Test Condition	Value	Unit
7.1	SSB phase noise power density at 10Hz offset	Typical at 10MHz	-95	dBc/Hz
7.2	SSB phase noise power density at 100kHz offset	Typical at 10MHz	-145	dBc/Hz

**8.0 LF TIMING PULSE**

Line	Parameter	Test Condition	Value	Unit
8.1	LF pulse width	Ripple counter setting (units=divider ratio). Note user programmable	4 to 64	
8.2	LF pulse width	LF timing pulse width = oscillator period/ripple	0.1 to 6.4	s
8.3	LF pulse period	Sync. counter setting (unit= sync. ratio). Note user programmable	2 to 4096	
8.4	LF pulse period	LF timing pulse period = oscillator period/ripple/sync.	0.2 to 26214.4	s
8.5	LF enable	LF enable setting (SPI or bonded in parallel to RF enable). Min = 0 (off). Max = 1 (on). Units= LF enabled. Note user programmable	0 to 1	

**9.0 COUNTER AND ALARM**

Line	Parameter	Description
9.1	32 bit timer	Continuous count of LF, reset on power up, read via SPI. 0 to $2^{32}-1$
9.2	32 bit timer	Rollover period = 4294967296 times LF period. 859s to 1303 days (unit= time)
9.3	32 bit match	Set via SPI which also resets alarm output when set. 0 to $2^{32}-1$
9.4	Alarm	Alarm latched when match detector matches timer. 0 to 1. For example the alarm can be set for periods of up to 50 days with 1ms resolution and with sub 1s accuracy

**10.0 FREQUENCY CHARACTERISTICS (DAC)**

Line	Parameter	Test Condition	Value	Unit
10.1	Frequency shift	At 0- relative to DAC 128. Minimum shift	-5 to -10	ppm
10.2	Frequency shift	At 0- relative to DAC 128. Maximum shift	-10 to -20	ppm
10.3	Frequency shift	At 255- relative to DAC 128. Minimum shift	5 to 10	ppm
10.4	Frequency shift	At 255- relative to DAC 128. Maximum shift	10 to 20	ppm
10.5	Frequency change per bit	Frequency (DAC 255 – DAC 0) / 256	0.04 to 0.2	ppm

**11.0 STANDARD 4 WIRE SPI INTERFACE (CPOL 0, CPHA 0 MODE)**

Line	Parameter	Description
11.1	Diagram	Refer to standard 4 wire SPI interface diagram
11.2	Digital control and LF output	Digital control information available on request

**12.0 MARKING**

Line	Parameter	Description
12.1	Line 1	R and manufacturing identifier (X XX) (see model drawing)
12.2	Line 2	Pad 1 / static sensitivity identifier ( $\Delta$ ), abbreviated part number (0000), device date code (YW) (see model drawing)
12.3		Laser marked

**13.0 PIN CONNECTIONS**

Line	Parameter	Description
13.1	Pin 1	SPI-CLK
13.2	Pin 2	SPI-IN
13.3	Pin 3	SPI-OUT
13.4	Pin 4	GND
13.5	Pin 5	+Vs*
13.6	Pin 6	RF out
13.7	Pin 7	ALARM
13.8	Pin 8	LF out
13.9	Pin 9	RF & LF enable
13.10	Pin 10	Supply, +Vs
13.11	Pin 11	DAC_OUT/VCXO*
13.12	Pin 12	SPI-EN
13.13	Note	* = No connection required, monitor points used during manufacture

**14.0 ENVIRONMENTAL SPECIFICATION**

Line	Parameter	Description
14.1	Storage temperature range	-55 to +125°C
14.2	Vibration	IEC 60068-2-6 test Fc, 20gn, 55-2000Hz, 4 hours per axis (12 hours total)
14.3	Shock	IEC 60068-2-27 test Ea, 1500g, 0.5ms, half-sine, 18 shocks total

## 15.0 MANUFACTURING INFORMATION

Line	Parameter	Description
15.1	Solderability	MIL-STD-202, method 208, category 3
15.2	Soldering	SMD product suitable for reflow soldering. Peak temperature 260°C. Maximum time above 220°C, 60 sec
15.3	Soldering	When soldering, ensure solder does not short top and bottom castellations
15.4	Materials	Part will not contain components with 'pure tin' terminations- part is assembled with lead-bearing solder. Termination finish: Au (0.5 to 1.27µm) over Ni (1.27 to 8.89µm) over tungsten on an alumina substrate

## 16.0 NOTES

Line	Parameter	Description
16.1	1	Frequency range available dependant on output type. Available in HCMOS output (3-40MHz) and clipped sinewave output (10-40MHz)
16.2	2	-20°C to 70°C ref. (Fmax +Fmin)/2. ±0.15 to 0.5 ppm. -40°C to 85°C ref. (Fmax +Fmin)/2. ±0.2 to 1 ppm. -55°C to 95°C ref. (Fmax +Fmin)/2. ±0.5 to 2 ppm.

Drawing Name: RFPT200 Model Drawing

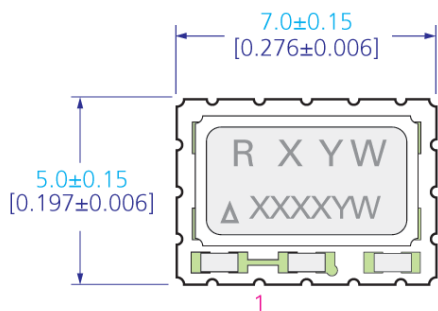

TOP VIEW

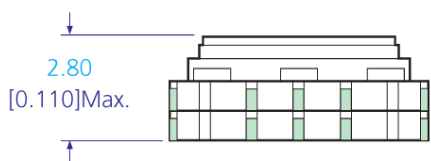

SIDE VIEW

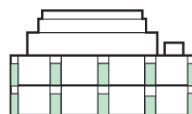

END VIEW

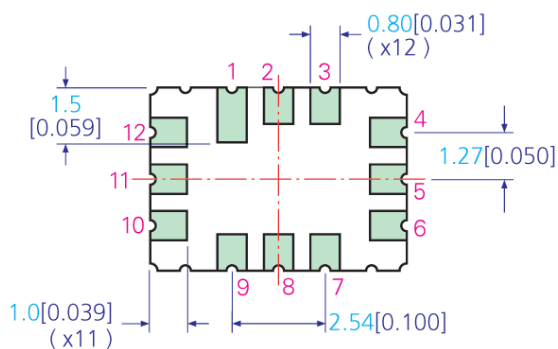

BOTTOM VIEW

NOTE: Pin connections are detailed in the specification

TITLE: RFPT200 MODEL OUTLINE DRAWING

FILENAME: RFPT200\_MD

RELATED DRAWINGS:

REVISION: A

DATE: 22-Jul-10

SCALE: 5 : 1

Millimeters [inch]

Tolerance:

XX = ±0.5

X.X = ±0.2

X.XX = ±0.10

X.XXX = ±0.05

X° = ±1.0°

Hole = ±0.10



©2009 Rakon Limited

Drawing Name: RFPT200 4 Wire SPI Timing Diagram

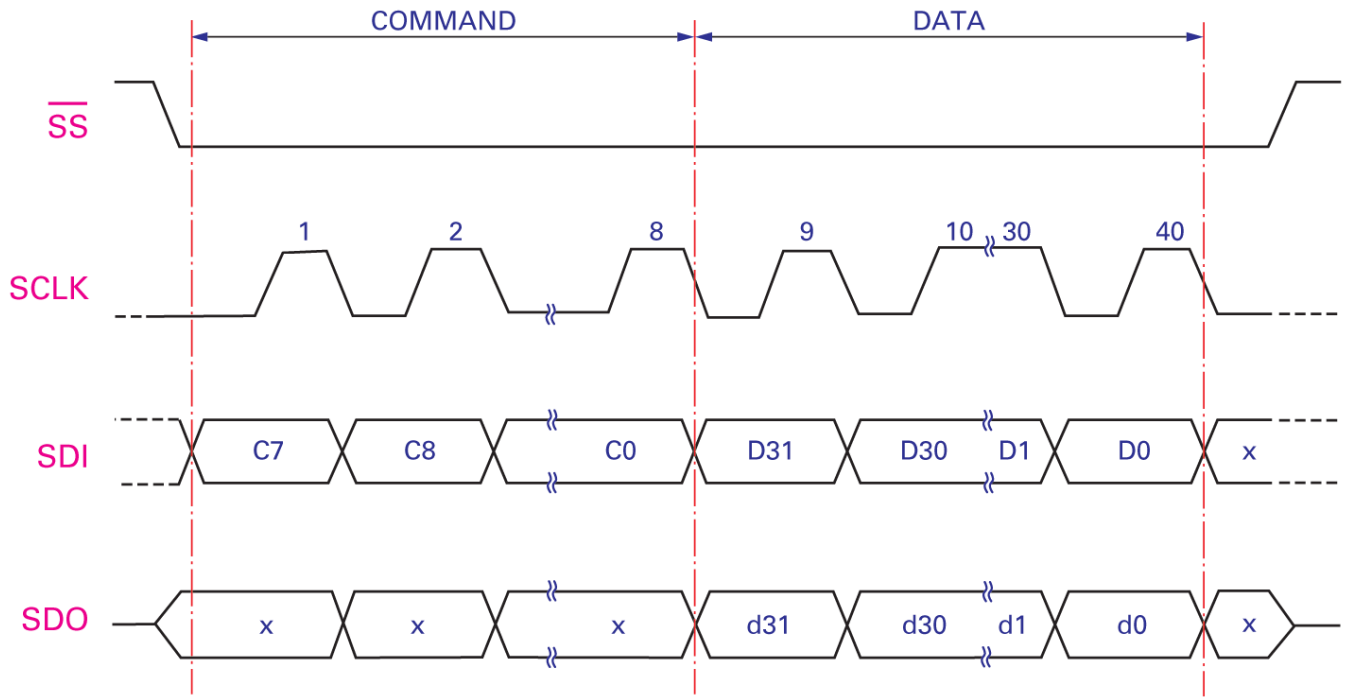

TITLE: RFPT200 4 WIRE SPI TIMING DIAGRAM

FILENAME: RFPT200\_4WI

RELATED DRAWINGS:

REVISION: A

DATE: 22-Jul-10

SCALE: NTS

Millimeters [inch]

Tolerance:

XX = ±0.5

X.X = ±0.2

X.XX = ±0.10

X.XXX = ±0.05

X° = ±1.0°

Hole = ±0.10

**rakon**

©2009 Rakon Limited

Drawing Name: RFPT200 Series Reflow Profile

Sn-Pb Eutectic Reflow Soldering Profile \*

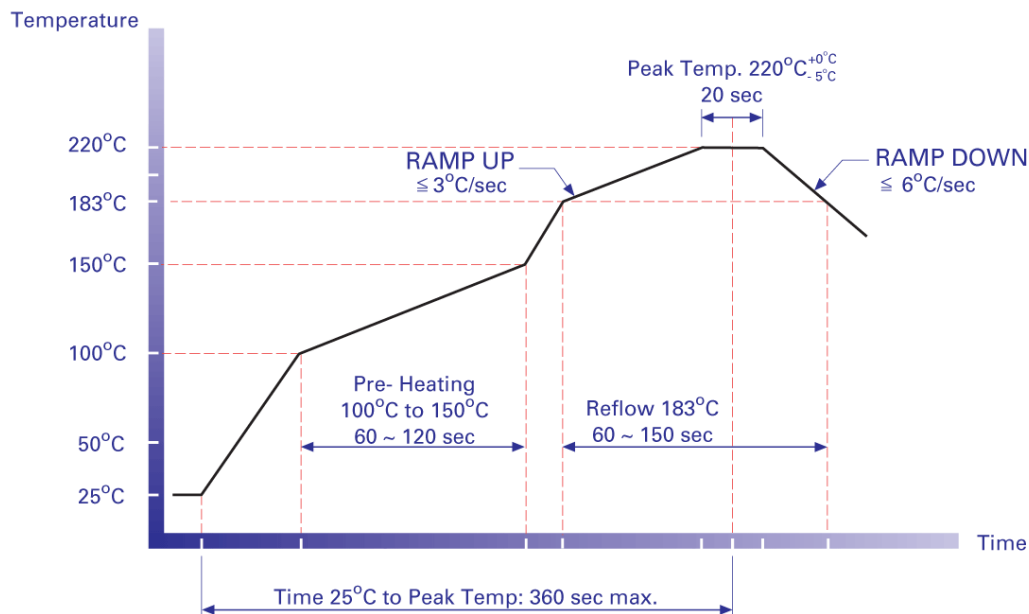

\* NOTE:

This profile was used during the qualification testing of the product and therefore represents worst case conditions. It is not recommended for use by the customer in the actual assembly of these parts.

TITLE: RFPT200 SERIES REFLOW PROFILE

FILENAME: RFPT200\_RF

RELATED DRAWINGS:

REVISION: A

DATE: 13-Sep-10

SCALE: NTS

Millimeters [inch]

Tolerance:

XX = ±0.5

X.X = ±0.2

X.XX = ±0.10

X.XXX = ±0.05

X<sup>o</sup> = ±1.0<sup>o</sup>

Hole = ±0.10

**rakon**

©2009 Rakon Limited

## Specification History

**Current Version : 1.01**

Version	User	Change	Note	Date
---------	------	--------	------	------