

RS1490D XO



`Tiger' SMD Clock Oscillator Series

High Performance Discrete Crystal Clock Oscillator.

Product description

This Discrete XO offers ultra low RMS phase jitter; phase noise and high frequency stability in an industry standard 14 x 9 mm SMD package.

Applications

- Basestation
- Communications
- DSL/ADSL
- IP timing
- Consumer Products
- SONET/SDH
- Other

Features

- LVPECL output
- HCMOS output

Specifications

1.0 SPECIFICATION REFERENCES

Line	Parameter	Description
1.1	Model Series	RS1490D XO
1.2	RoHS Compliant	Yes
1.3	Custom P#	
1.4	Package Type	P6, P4, M6 or M4 - select only one

2.0 FREQUENCY CHARACTERISTICS

Line	Parameter	Test Condition	Value	Unit
2.1	Frequency Range		10 to 180	MHz
2.2	Operating Temperature Range	(Note 1)	-40 to 85	°C
2.3	Frequency Stability	Including temperature range, Supply variation, Load variation and 15 years Aging	±15 to 50	ppm

3.0 POWER SUPPLY

Line	Parameter	Test Condition	Value	Unit
3.1	Supply Voltage	With a tolerance of ±10%	2.97 to 5.5	V
3.2	Supply Current	(Note 2)	10 to 120	mA

4.0 OUTPUT CHARACTERISTICS - PECL/LVPECL ONLY

Line	Parameter	Test Condition	Value	Unit
4.1	Output	PECL/LVPECL		
4.2	Duty Cycle	@ VCC -1.3 V	40 to 60	%
4.3	Output Load	With VCC - 2 V @ 50Ω		
4.4	Rise time / fall time	80%/20% (Note 3)	0.5 to 3	ns
4.5	Logic `1' on Pad 2	Tristate GND (Note 4)		
4.6	Logic `0' on Pad 2	Enable (VCC or open) (Note 4)		
4.7	RMS Phase Jitter	Integrated 12 KHz to 20 MHz. Typical @ 155.52 MHz (Note 5)	0.5 max	ps
4.8	RMS Period Jitter	Typical @ 155.52 MHz (Note 5)	3 max	ps
4.9	Sub-harmonics		-30 max	dBc

5.0 OUTPUT CHARACTERISTICS - CMOS/LVCMOS ONLY

Line	Parameter	Test Condition	Value	Unit
5.1	Output	CMOS/LVCMOS		
5.2	Duty Cycle	@ 50% VCC	40 to 60	%
5.3	Output Load		15 to 50	pF
5.4	Rise time / fall time	90%/10% (Note 3)	0.5 to 3	ns
5.5	Logic `0' on Pad 2	Tristate GND (Note 4)		
5.6	Logic `1' on Pad 2	Enable (VCC or open) (Note 4)		
5.7	RMS Phase Jitter	Integrated 12 KHz to 20 MHz. Typical @ 155.52 MHz (Note 5)	0.5 max	ps
5.8	RMS Period Jitter	Typical @ 155.52 MHz (Note 5)	3 max	ps
5.9	Sub-harmonics		-30 max	dBc

6.0 OUTPUT CHARACTERISTICS - LVDS ONLY UP TO 3.3V

Line	Parameter	Test Condition	Value	Unit
6.1	Output	LVDS		
6.2	Duty Cycle	Measured at 1.25 V	40 to 60	%
6.3	Output load	RL = 100 Ω / CL = 10 pF		
6.4	Rise time/ fall time	RL = 100 Ω / CL = 10 pF (Note 3)	0.5 to 3	ns
6.5	Logic `0' on Pad 2	Tristate GND (Note 4)		
6.6	Logic `1' on Pad 2	Enable (VCC or open) (Note 4)		
6.7	RMS Phase Jitter	Integrated 12 Hz to 20 MHz. Typical @ 155.52 MHz (Note 5)	0.5 max	ps
6.8	RMS Period Jitter	Typical @ 155.52 MHz (Note 5)	3 max	ps
6.9	Sub-harmonics		-30 max	dBc

7.0 SSB PHASE NOISE

Line	Parameter	Test Condition	Value	Unit
7.1	SSB Phase Noise power density @ 10 Hz offset	Value for a 24.576 MHz XO @ 25°C	-80	dBc/Hz
7.2	SSB Phase Noise power density @ 100 Hz offset	Value for a 24.576 MHz XO @ 25°C	-105	dBc/Hz
7.3	SSB Phase Noise power density @ 1 KHz offset	Value for a 24.576 MHz XO @ 25°C	-130	dBc/Hz
7.4	SSB Phase Noise power density @ 10 KHz offset	Value for a 24.576 MHz XO @ 25°C	-152	dBc/Hz
7.5	SSB Phase Noise power density @ 100 KHz offset	Value for a 24.576 MHz XO @ 25°C	-157	dBc/Hz

8.0 SSB PHASE NOISE

Line	Parameter	Test Condition	Value	Unit
8.1	SSB Phase Noise power density @ 10 Hz offset	Value for a 77.76 MHz XO @ 25°C	-78	dBc/Hz
8.2	SSB Phase Noise power density @ 100 Hz offset	Value for a 77.76 MHz XO @ 25°C	-102	dBc/Hz
8.3	SSB Phase Noise power density @ 1 KHz offset	Value for a 77.76 MHz XO @ 25°C	-127	dBc/Hz
8.4	SSB Phase Noise power density @ 10 KHz offset	Value for a 77.76 MHz XO @ 25°C	-152	dBc/Hz
8.5	SSB Phase Noise power density @ 100 KHz offset	Value for a 77.76 MHz XO @ 25°C	-157	dBc/Hz

9.0 SSB PHASE NOISE

Line	Parameter	Test Condition	Value	Unit
9.1	SSB Phase Noise power density @ 10 Hz offset	Value for a 155.52 MHz XO @ 25°C	-75	dBc/Hz
9.2	SSB Phase Noise power density @ 100 Hz offset	Value for a 155.52 MHz XO @ 25°C	-100	dBc/Hz
9.3	SSB Phase Noise power density @ 1 KHz offset	Value for a 155.52 MHz XO @ 25°C	-125	dBc/Hz
9.4	SSB Phase Noise power density @ 10 KHz offset	Value for a 155.52 MHz XO @ 25°C	-150	dBc/Hz
9.5	SSB Phase Noise power density @ 100 KHz offset	Value for a 155.52 MHz XO @ 25°C	-155	dBc/Hz

10.0 ENVIRONMENTAL SPECIFICATION

Line	Parameter	Description
10.1	SMD	Product suitable for Pb-free convection reflow soldering, compliant with JEDEC standard. J-STD-020, Level 1.
10.2	Storage Temperature Range	-55 to 125°C
10.3	Sealing	Non-hermetic package
10.4	Shock	981ms ⁻² (100gn) acceleration for 6ms duration, 3 shocks in each direction along 3 mutually perpendicular axis. IEC 60068-2-27 Test Ea
10.5	Vibration	10-60Hz 0.75mm displacements, 60-500Hz 98.1ms ⁻² (10gn) acceleration. 30 minutes in each of three mutually perpendicular planes at 1 octave per minute. IEC 60068-2-6 Test Fc Procedure B4
10.6	Marking	Resistant to all common solvents
10.7	RoHS	Parts are fully compliant with the European Union Directive 2002/95/EC on the restriction of the use of certain hazardous substances in electrical and electronic equipment. Note: The RoHS compliant parts are suitable for assembly using both Lead-free solders and Tin/Lead solders.

11.0 MANUFACTURING INFORMATION

Line	Parameter	Description
11.1	Packing Description	Tape and reel as shown
11.2	Reflow	Solder reflow process as per attached profile

12.0 SPECIFICATION NOTES

Line	Parameter	Description
12.1	Note 1	The operating temperature range needs to be specified.
12.2	Note 2	Output current depends on the frequency selected and the output characteristic chosen
12.3	Note 3	The exact value will be frequency dependant
12.4	Note 4	Enable high or low is available as an option
12.5	Note 5	The jitter values will vary depending on the frequency selected

Drawing Name: RS/RV1490 Metal Model Drawing

MODEL OUTLINE (M6 & M4)

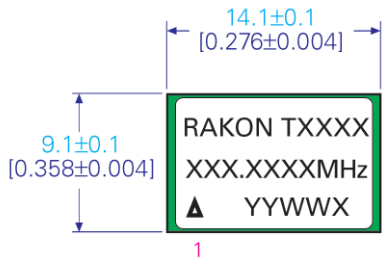

TOP VIEW

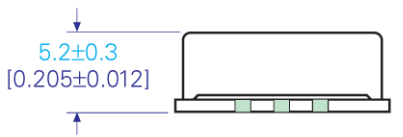

SIDE VIEW (6 PAD)

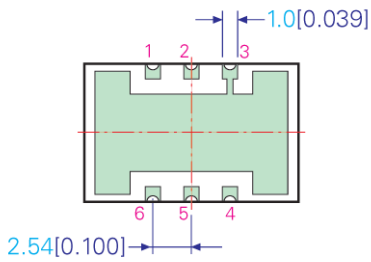

BOTTOM VIEW (6 PAD)

RECOMMENDED PAD LAYOUT - M6

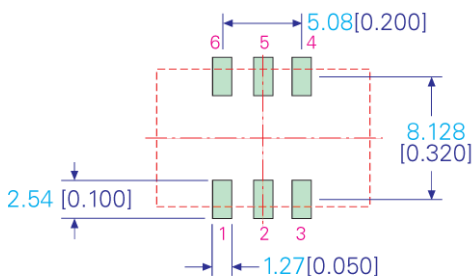

PIN CONNECTIONS

M6		
PIN	VCXO & XO (LVPECL/LVDS)	VCXO (LV/HCMOS)
1	VCO (VCXO only) E/D or NC (XO only)	VCO
2	E/D or NC	E/D or NC
3	GND	GND
4	OUTPUT	OUTPUT
5	OUTPUT	NC
6	VCC	VCC

M4	
PIN	VCXO & XO (LV/HCMOS)
1	VCO (VCXO only) E/D or NC (XO only)
2	GND
3	OUTPUT
4	VCC

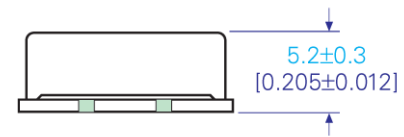

SIDE VIEW (4 PAD)

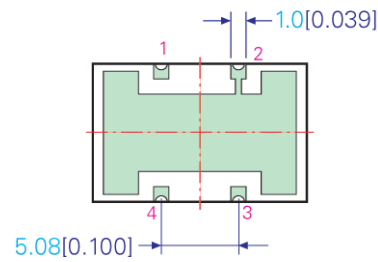

BOTTOM VIEW (4 PAD)

RECOMMENDED PAD LAYOUT -M4

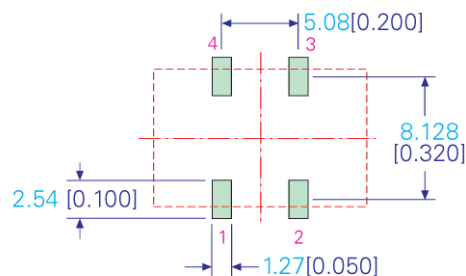

TITLE: RV/RS1490 METAL MODEL DRAWING

RELATED DRAWINGS:

FILENAME: CAT525

REVISION: A

DATE: 16-Sep-09

SCALE: 2 : 1

Millimetres [inch]

Tolerance:

XX = ±0.5

X.X = ±0.2

X.XX = ±0.10

X.XXX = ±0.05

X° = ±1.0°

Hole = ±0.10



©2009 Rakon Limited

Drawing Name: RS/RV1490 Plastic Model Drawing

MODEL OUTLINE (P6 & P4)

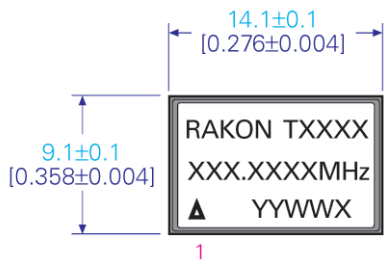

TOP VIEW

PIN CONNECTIONS

P6			P4	
PIN	VCXO & XO (LVPECL/LVDS)	VCXO (LV/HCMOS)	PIN	VCXO & XO (LV/HCMOS)
1	VCO (VCXO only) E/D or NC (XO only)	VCO	1	VCO (VCXO only) E/D or NC (XO only)
2	E/D or NC	E/D or NC	2	GND
3	GND	GND	3	OUTPUT
4	OUTPUT	OUTPUT	4	VCC
5	OUTPUT	NC		
6	VCC	VCC		

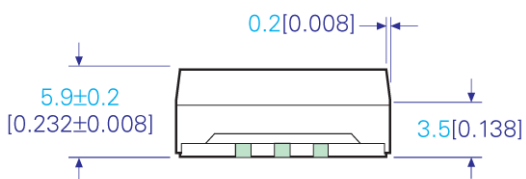

SIDE VIEW (6 PAD)

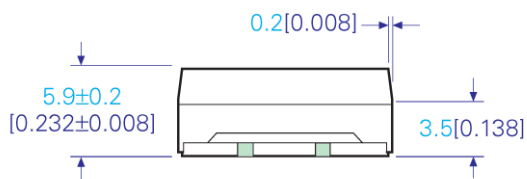

SIDE VIEW (4 PAD)

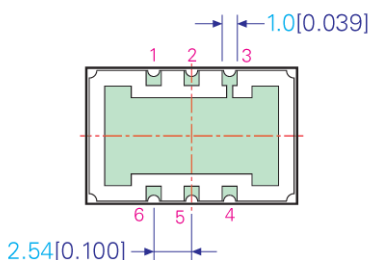

BOTTOM VIEW (6 PAD)

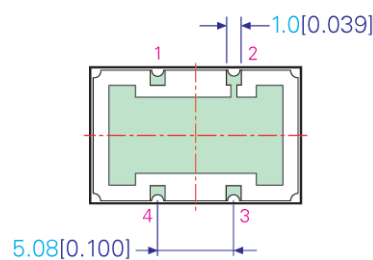

BOTTOM VIEW (4 PAD)

RECOMMENDED PAD LAYOUT - P6

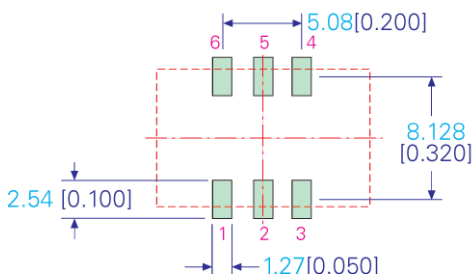

RECOMMENDED PAD LAYOUT - P4

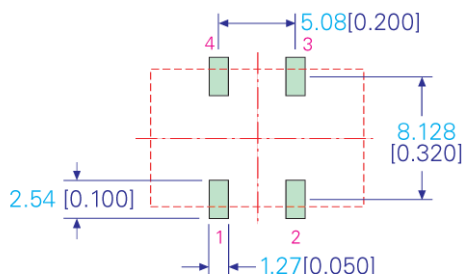

TITLE: RV/RS1490 PLASTIC MODEL DRAWING

RELATED DRAWINGS:

FILENAME: CAT519

REVISION: A

DATE: 16-Sep-09

SCALE: 2 : 1

Millimetres [inch]

Tolerance:

XX = ±0.5

X.X = ±0.2

X.XX = ±0.10

X.XXX = ±0.05

X° = ±1.0°

Hole = ±0.10



©2009 Rakon Limited

Drawing Name: RS/RV 1490 Series Marking

GENERAL MARKING

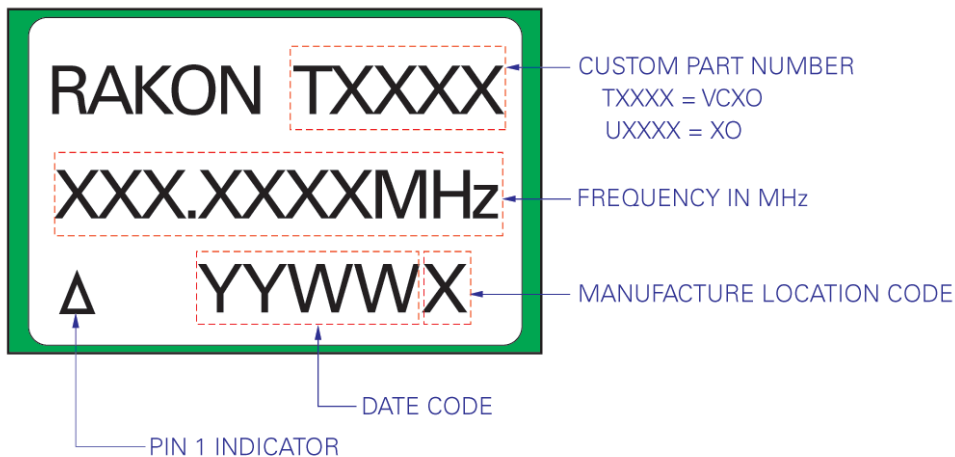

MARKING EXAMPLE

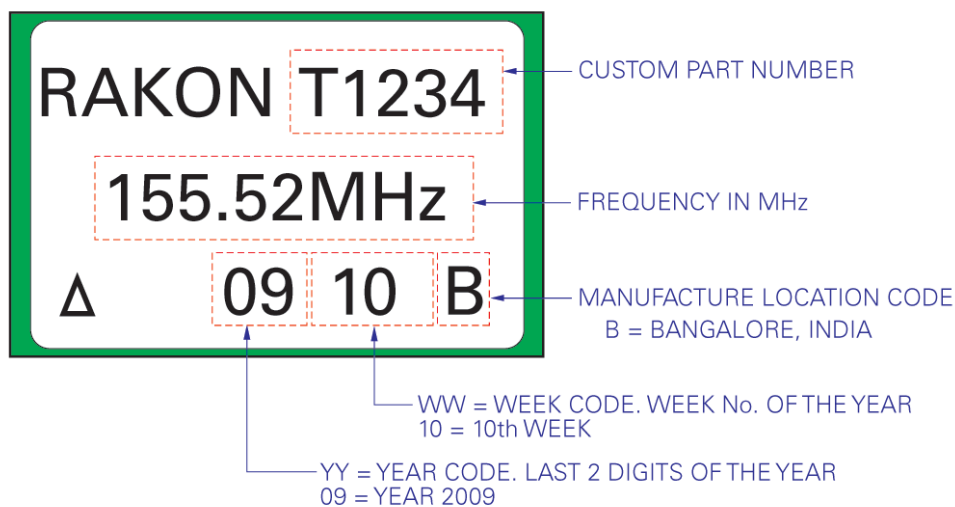

TITLE: RS/RV 1490 SERIES MARKING

RELATED DRAWINGS:

FILENAME: CAT524

REVISION: A

DATE: 16-Sep-09

SCALE: 5 : 1

Millimeters [inch]

Tolerance:

XX = ±0.5

X.X = ±0.2

X.XX = ±0.10

X.XXX = ±0.05

X^o = ±1.0°

Hole = ±0.10



©2009 Rakon Limited

Drawing Name: TC-CAT521

HC MOS TEST CIRCUIT :

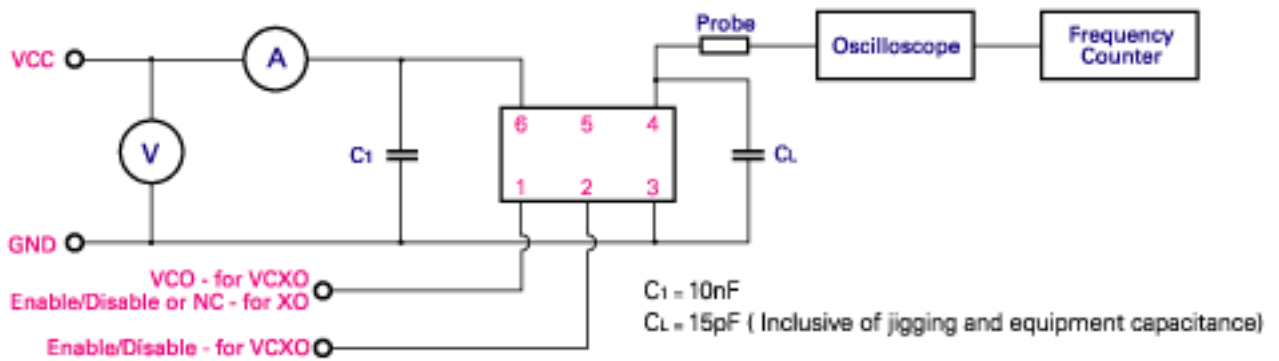

LVPECL TEST CIRCUIT :

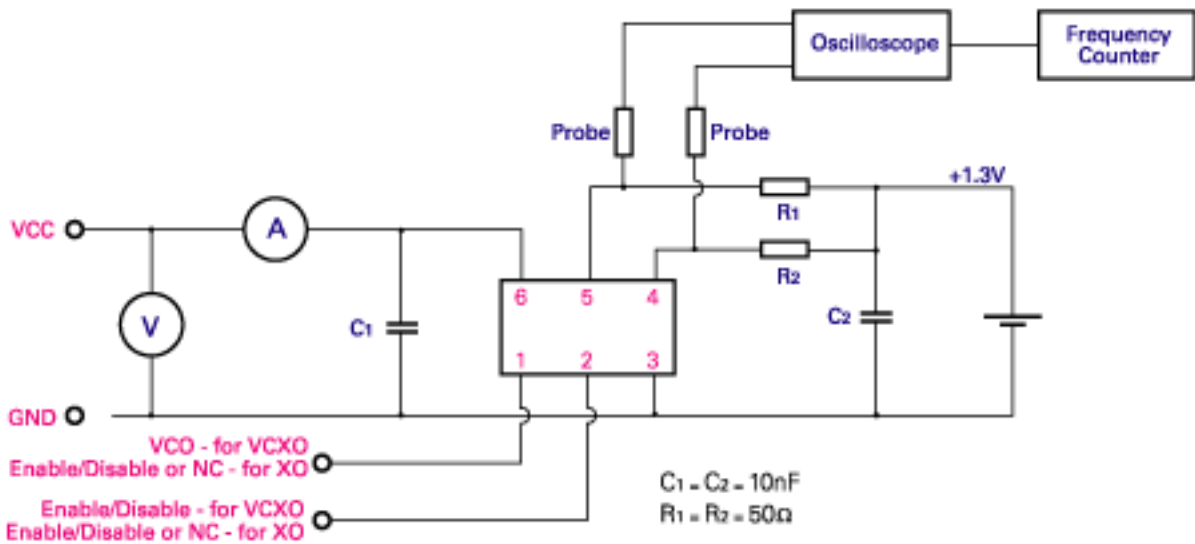

LVDS TEST CIRCUIT :

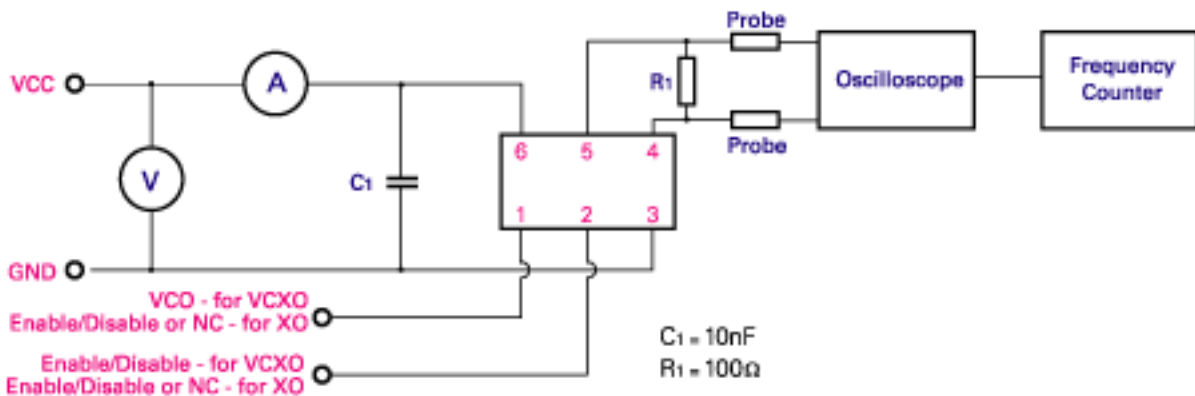

TITLE: RV/RS1490 SERIES TEST CIRCUIT

RELATED DRAWINGS:

FILENAME: CAT521

REVISION: A

DATE: 16-Sep-09

SCALE: NTS

Millimetres [inch]

rakon

©2009 Rakon Limited

Drawing Name: TR-CAT522

TAPE DETAIL (SCALE 2 : 1)

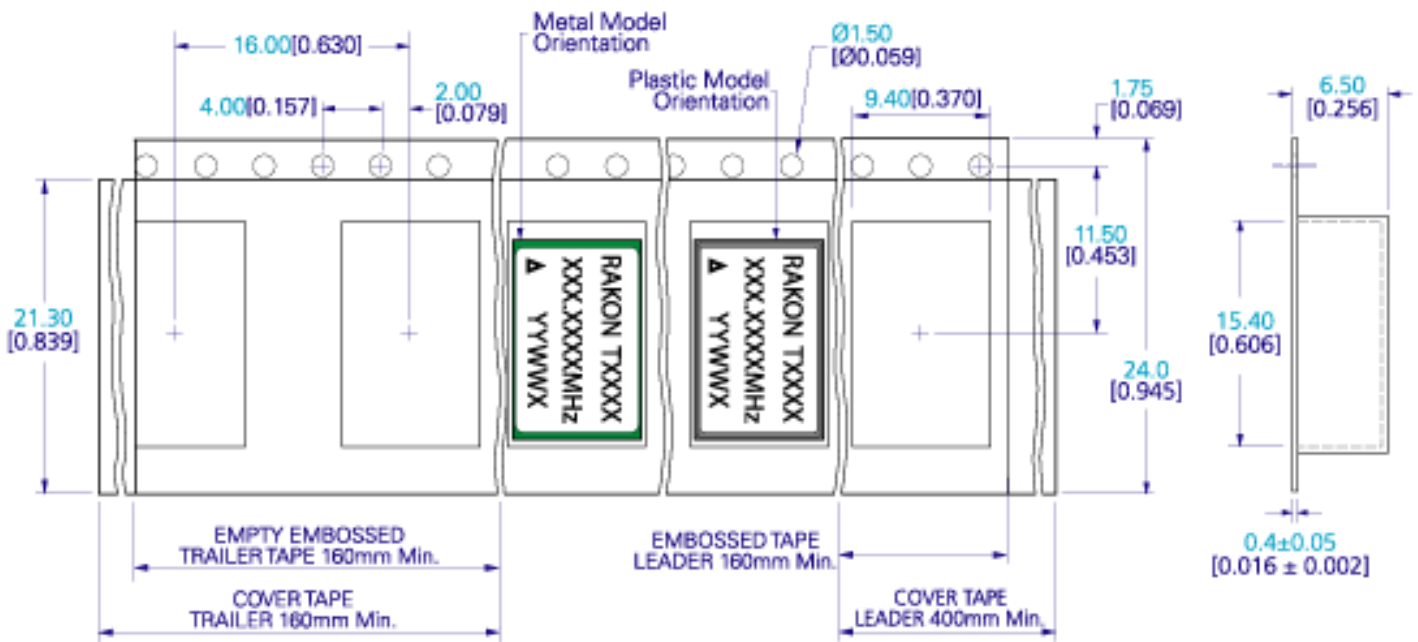

REEL DETAIL (SCALE 1 : 5)

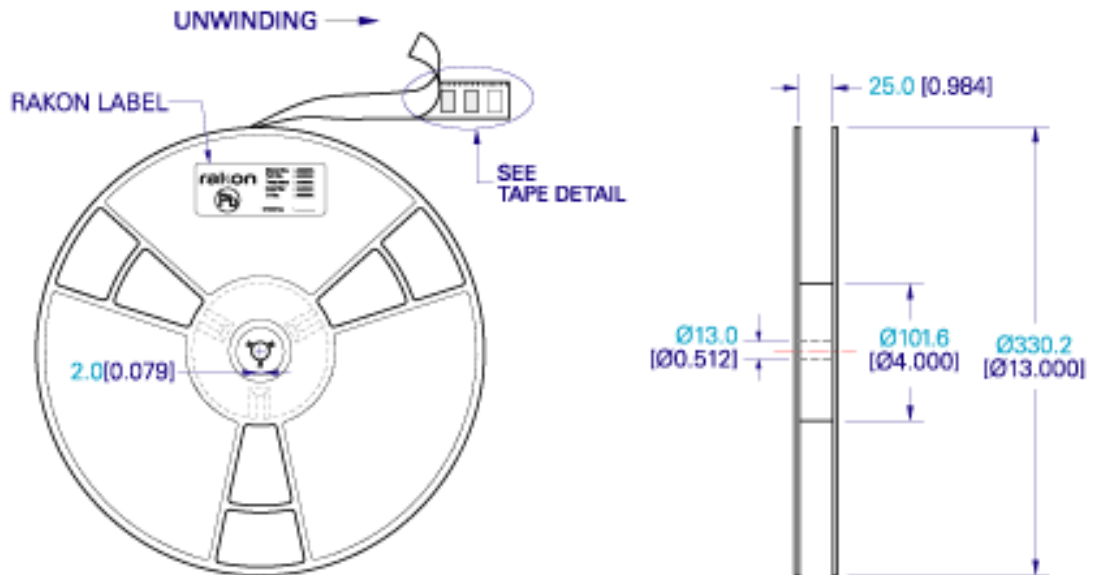

NOTE: Ø330mm REEL'S STANDARD PACKING QUANTITY IS 500 OSCILLATORS PER REEL.

TITLE: RV/RS1490 SERIES TAPE & Dia.330 REEL

RELATED DRAWINGS:

FILENAME: CAT522

REVISION: A

DATE: 16-Sep-09

SCALE: See above

Millimetres [inch]

Tolerance:

XX = ±0.5

X.X = ±0.2

X.XX = ±0.10

X.XXX = ±0.05

X° = ±1.0°

Hole = ±0.10

rakon

©2009 Rakon Limited

Drawing Name: RF-CAT523

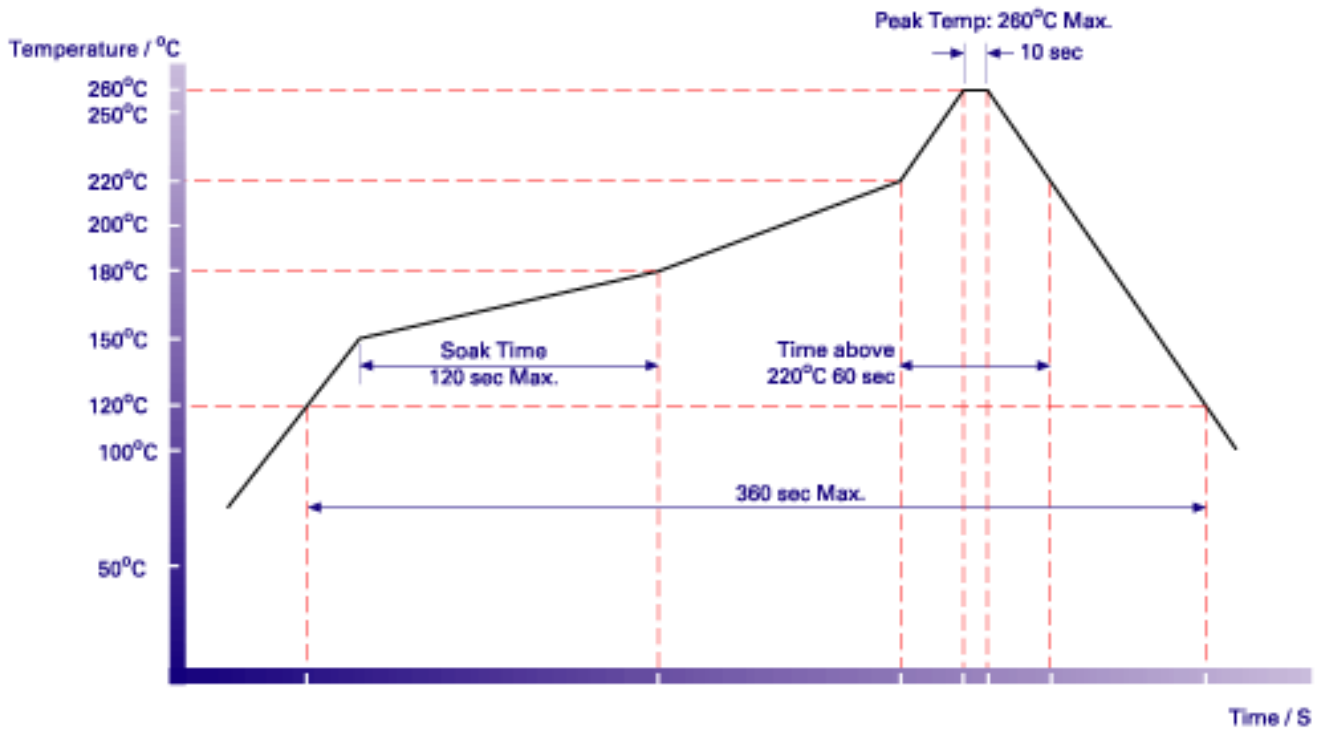

NOTE:

The product has been tested to withstand the Reflow Profile shown. The Reflow Profile used to solder Rakon VCXO/XO is determined by the solder paste manufacturer's specification. It is recommended that the Reflow Profile used does not exceed the one shown above.

TITLE: RV/RS1490 SERIES Pb-FREE REFLOW

RELATED DRAWINGS:

FILENAME: CAT523

REVISION: A

DATE: 16-Sep-09

SCALE: NTS

Millimetres [inch]

rakon

©2009 Rakon Limited

Specification History

Current Version : 1.01

Version	User	Change	Note
---------	------	--------	------