

RTX7050A

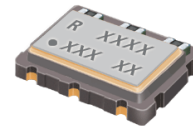

SMD Temperature Compensated Crystal Oscillator

High performance TCXO offering excellent Phase Noise, Frequency Stability and VCO tilt compensation.



Product description

The RTX7050A employs an analogue IC for the oscillator and temperature compensation. 7 mm x 5 mm in size.

Applications

- Basestation
- Communications
- DSL/ADSL
- Femtocell
- IP timing
- LTE
- Precision GPS
- SONET/SDH
- WiMAX/WiBro
- WLAN
- Other

Features

- Excellent phase noise performance
- Excellent temperature stability
- Frequency slope and perturbation specifications can be customized to the application requirement
- Clipped sinewave or CMOS output options

Specifications

1.0 SPECIFICATION REFERENCES

Line	Parameter	Description
1.1	Model description	RTX7050A (Preliminary)
1.2	RoHS compliant	Yes
1.3	Filter	Enabled/Disabled
1.4	Reference number	
1.5	Rakon part number	

2.0 FREQUENCY CHARACTERISTICS

Line	Parameter	Test Condition	Value	Unit
2.1	Frequency	Nominal frequency	5 to 52	MHz
2.2	Frequency calibration	Offset from nominal frequency measured at 25°C ± 2°C	±1 max	ppm
2.3	Reflow shift	Two consecutive reflows as per attached profile after 1 hour recovery 25°C	±1 max	ppm
2.4	Frequency stability over temperature	Referenced to the midpoint between minimum and maximum frequency value over the specified temperature range (Note 1, 2)	±0.1 to 3	ppm
2.5	Temperature range	The operating temperature range over which the frequency stability is measured	-40 to 85	°C
2.6	Frequency slope	Minimum of 1 frequency reading every 2°C, over the operating temperature range (Note 1, 2)	0.1 max	ppm/°C
2.7	Static temperature hysteresis	Frequency change after reciprocal temperature ramped over the operating range. Frequency measured before and after at 25°C	0.4 max	ppm
2.8	Supply voltage stability	Supply voltage varied ±5% at 25°C	±0.1 max	ppm
2.9	Load sensitivity	±10% load change (Note 3)	±0.2 max	ppm
2.10	Long term stability	Frequency drift over 1 year 25°C	±1 max	ppm

3.0 POWER SUPPLY

Line	Parameter	Test Condition	Value	Unit
3.1	Supply voltage	Nominal supply voltage range	2.8 to 5.5	V
3.2	Current	At maximum supply voltage (Note 3)	2.9 max	mA

4.0 CONTROL VOLTAGE (VCO) OPTION

Line	Parameter	Test Condition	Value	Unit
4.1	Control voltage range	The nominal control voltage value is midway between the minimum and maximum (Note 4)	0.5 to 4.5	V
4.2	Frequency tuning	Frequency shift from minimum to maximum control voltages	6 to 30	ppm
4.3	Port input impedance		100 min	k Ω
4.4	Frequency tuning linearity	Deviation from straight line curve fit	10 max	%

5.0 OSCILLATOR OUTPUT - CS OPTION

Line	Parameter	Test Condition	Value	Unit
5.1	Output waveform	AC coupled clipped sine-wave		
5.2	Output voltage level	At minimum supply voltage (Note 3)	0.8 min	V
5.3	Output load resistance	Operating range	9 to 11	k Ω
5.4	Output load capacitance	Operating range	9 to 11	pF
5.5	Start up time (amplitude)	Time taken for output to reach 90% of specified output level	1 max	ms
5.6	Settling time (frequency)	Time taken for frequency to reach specified calibration tolerance (Note 5)	10 max	ms

6.0 OSCILLATOR OUTPUT - CMOS OPTION

Line	Parameter	Test Condition	Value	Unit
6.1	Output waveform	HCMOS		
6.2	Output voltage level low	Measured with a capacitive load of 10pF	10 max	%Vcc
6.3	Output voltage level high	Measured with a capacitive load of 10pF	90 min	%Vcc
6.4	Rise and fall times	Measured with a capacitive load of 10pF	5 max	ns
6.5	Duty cycle	Measured at 50% Vcc trigger level	40 to 60	%
6.6	Output load		10 max	pF
6.7	Settling time (frequency)	Time taken for frequency to reach specified calibration tolerance (Note 5)		

7.0 SSB PHASE NOISE

Line	Parameter	Test Condition	Value	Unit
7.1	SSB phase noise power density at 1Hz offset	Typical value for a 10.0MHz Oscillator at 25°C. CMOS output	-75	dBc/Hz
7.2	SSB phase noise power density at 10Hz offset	Typical value for a 10.0MHz Oscillator at 25°C. CMOS output	-98	dBc/Hz
7.3	SSB phase noise power density at 100Hz offset	Typical value for a 10.0MHz Oscillator at 25°C. CMOS output	-127	dBc/Hz
7.4	SSB phase noise power density at 1kHz offset	Typical value for a 10.0MHz Oscillator at 25°C. CMOS output	-147	dBc/Hz
7.5	SSB phase noise power density at 10kHz offset	Typical value for a 10.0MHz Oscillator at 25°C. CMOS output	-152	dBc/Hz
7.6	SSB phase noise power density at 100kHz offset	Typical value for a 10.0MHz Oscillator at 25°C. CMOS output	-155	dBc/Hz
7.7	SSB phase noise power density at 1MHz offset	Typical value for a 10.0MHz Oscillator at 25°C. CMOS output	-157	dBc/Hz

8.0 ENVIRONMENTAL

Line	Parameter	Description
8.1	Shock	Half sine wave acceleration of 100G peak amplitude for 6ms duration, 3 cycles each plane. IEC 60068-2-27 (Note 6).
8.2	Humidity	After 48 hours at 85°C ± 2°C 85% relative humidity non-condensing (Note 6).
8.3	Thermal shock	Exposed at -40°C for 30 minutes then to 85°C for 30 minutes constantly for a period of 5 days (Note 12).
8.4	Vibration	10G RMS from 30Hz to 1500Hz random in each of the 3 axis for 4 hours, total 12 hours (Note 6).
8.5	Storage temperature	-40 to 85°C.

9.0 MARKING

Line	Parameter	Description
9.1	Type	Engraved.
9.2	Line 1	R and product code.
9.3	Line 2	Pin 1 and date code.

10.0 MANUFACTURING INFORMATION

Line	Parameter	Description
10.1	Reflow	Solder reflow processes as per attached profile.
10.2	Packaging description	Tape and reel. Standard packing quantity is 2000 units per reel

11.0 SPECIFICATION NOTES

Line	Parameter	Description
11.1	Note 1	Temperature varied at maximum of 1°C per minute. Control voltage held at midpoint.
11.2	Note 2	Parts should be shielded from drafts causing unexpected thermal gradients. Temperature changes due to ambient air currents on the oscillator can lead to short term frequency drift.
11.3	Note 3	Specified for load stated in oscillator output section
11.4	Note 4	VCO of 4.5V only applicable when Vcc of 5.0V is applied.
11.5	Note 5	Specification assumes that no phase noise filtering. If low phase noise is required, frequency settling time will be extended. Full details are available from your Rakon sales office.
11.6	Note 6	The environmental condition will cause less than 1ppm shift in frequency.
11.7		

Drawing Name: RTX7050A Model Drawing

MODEL DRAWING

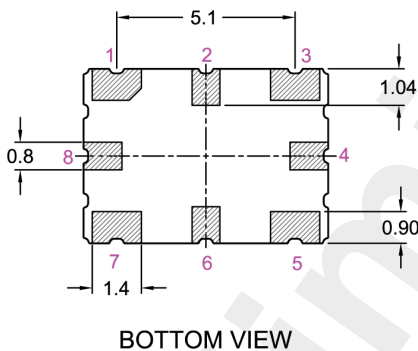
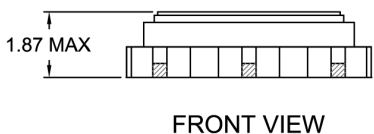
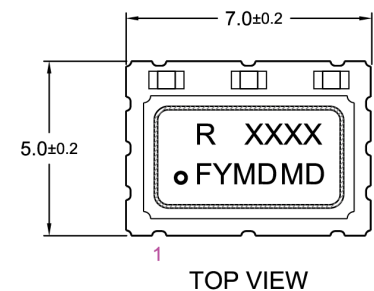

MARKING EXAMPLE

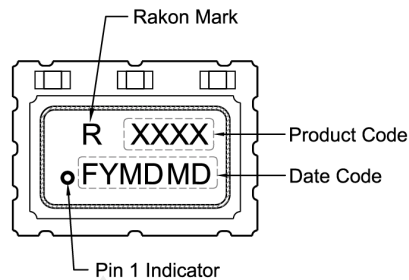

PIN CONNECTIONS

Pin	Without VC	With VC
1	NC	VCO
2	NC	NC
3	GND	GND
4	NC	NC
5	OUTPUT	OUTPUT
6	NC	NC
7	VCC	VCC
8	NC	NC

RECOMMENDED PAD LAYOUT - TOP VIEW

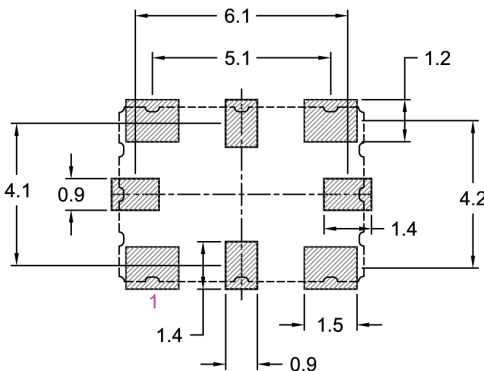

TITLE: RTX7050A MODEL

RELATED DRAWINGS:

FILENAME: CAT570

REVISION: B

DATE: 23-Aug-11

SCALE: 5 : 1

Millimetres [inch]

TOLERANCES:

±0.13

UNLESS OTHERWISE SPECIFIED

rakon

© 2009 Rakon Limited

Drawing Name: RTX7050 Series Test Circuit

NO VOLTAGE CONTROL INPUT:

C1: 100nF.
F1: A ferrite bead or a resistor between 22Ω ~ 47Ω recommended.

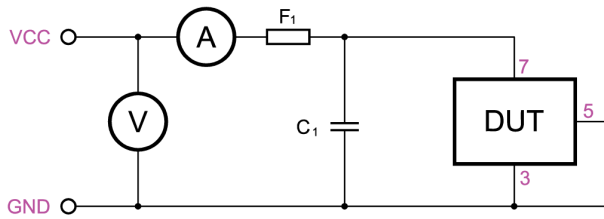

VOLTAGE CONTROL INPUT:

C1: 100nF.
F1: A ferrite bead or a resistor between 22Ω ~ 47Ω recommended.

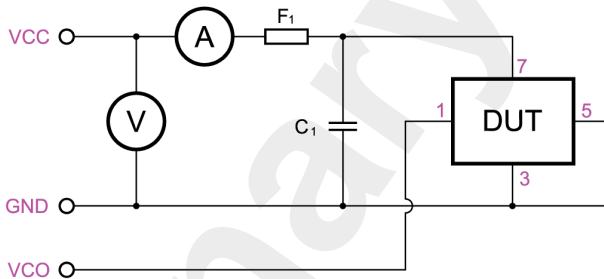

CLIPPED SINEWAVE OUTPUT:

RL: 10k
CT: CL + C2 (C2 - Oscilloscope probe capacitance)
CT as stated in OSCILLATOR OUTPUT section

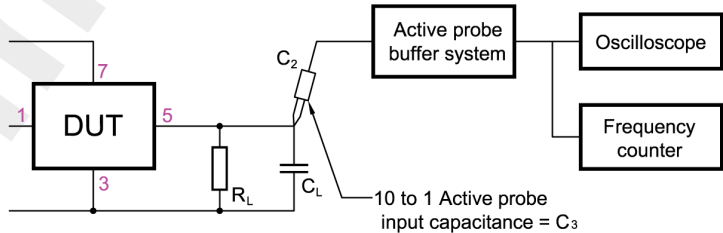

CMOS OUTPUT:

CT: CL + C2 (C2 - Oscilloscope probe capacitance)
CT as stated in OSCILLATOR OUTPUT section

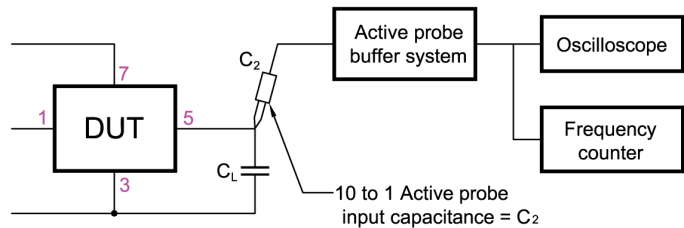

TITLE: RTX7050 SERIES TEST CIRCUIT

FILENAME: CAT578

RELATED DRAWINGS:

REVISION: B

DATE: 11-Mar-11

SCALE: 1 : 1

Millimetres [inch]



© 2009 Rakon Limited

Drawing Name: RTX7050 Series Tape & Reel

TAPE DETAILS (Scale 2 : 1)

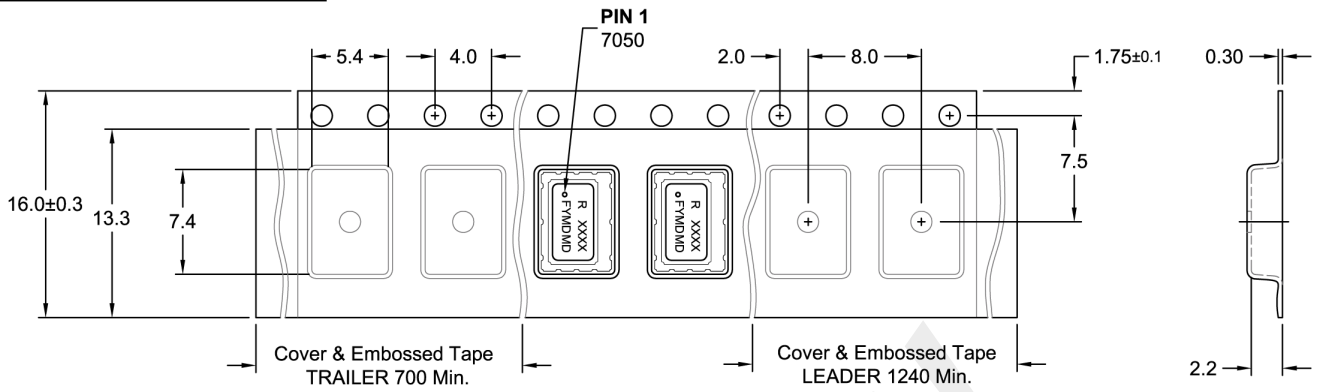

REEL DETAILS (Scale 1 : 2.5)

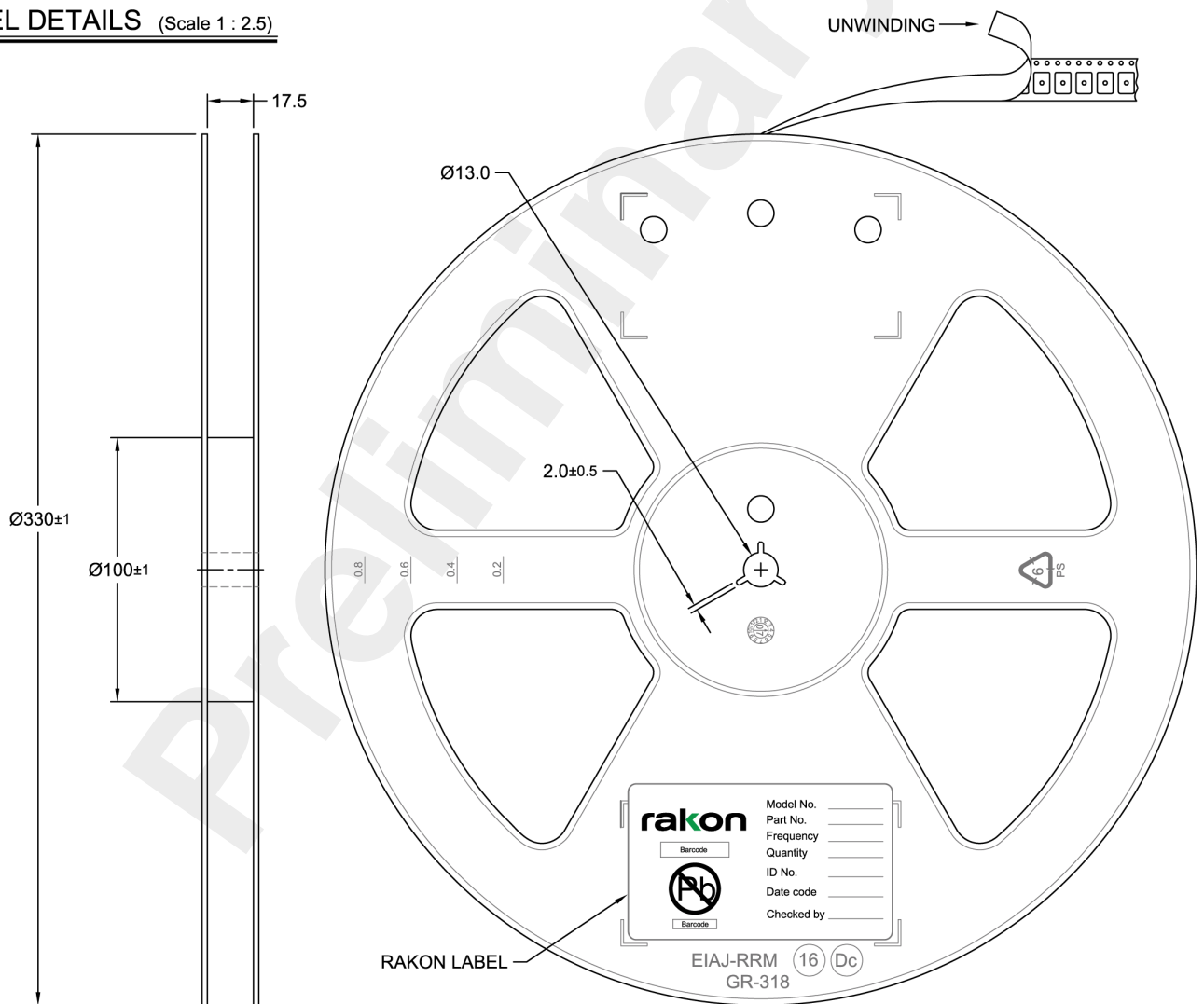

TITLE: RTX7050 SERIES TAPE & REEL

RELATED DRAWINGS:

FILENAME: CAT579

REVISION: B

DATE: 23-Aug-11

SCALE: 2 : 1

Millimetres [inch]

TOLERANCES:

X.X = ± 0.1

X.XX = ± 0.05

UNLESS

OTHERWISE

SPECIFIED

rakon

© 2009 Rakon Limited

Drawing Name: Pb-Free Reflow

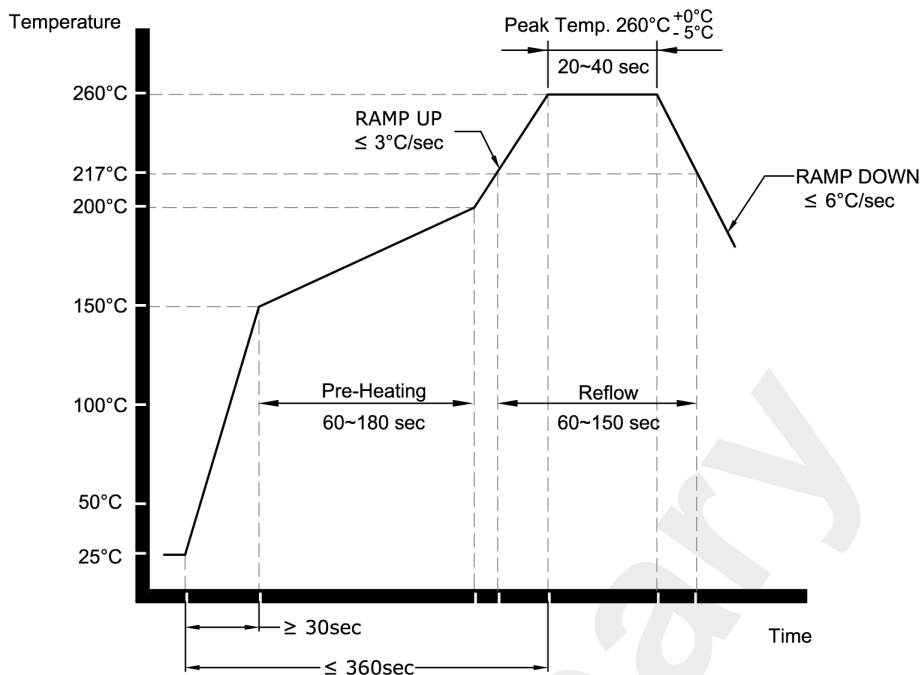

NOTE:

The product has been tested to withstand the Reflow Profile shown. The Reflow Profile used to solder Rakon products is determined by the solder paste Manufacturer's specification. It is recommended that the Reflow Profile used does not exceed the one shown above.

TITLE: Pb-FREE REFLOW

RELATED DRAWINGS:

FILENAME: CAT541

REVISION: B

DATE: 07-Apr-10

SCALE: NTS

Millimetres [inch]



© 2009 Rakon Limited