

# RXO7050R



## SMD Clock Oscillator

High performance XO in 7 x 5 mm Surface Mount package

### Product description

This XO combines high performance with fast lead-times. The ultra low RMS phase jitter, tight frequency stability and tight duty cycle is ideal for many high speed serial data communications, networking and telecom applications.

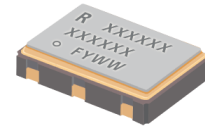

### Applications

- Basestation
- Communications
- Consumer Products
- DSL/ADSL
- Ethernet
- WiFi
- WiMAX/WLAN
- Other

### Features

- <1ps integrated RMS phase jitter (12 kHz to 20 MHz)
- Fast sample turnaround available
- LVCMOS, LVPECL or LVDS Output options
- Low cost
- Wide frequency range

### Specifications

#### 1.0 SPECIFICATION REFERENCES

Line	Parameter	Description
1.1	Model Description	RXO7050R XO
1.2	RoHS Compliant	Yes
1.3	Reference Number	
1.4	Internal Part Number	
1.5	Package Type	Package B

#### 2.0 FREQUENCY CHARACTERISTICS

Line	Parameter	Test Condition	Value	Unit
2.1	Frequency		8 to 1500	MHz
2.2	Operating Temperature Range		-40 to 85	°C
2.3	Frequency Stability	Including Temperature range, Supply variation, Load variation and 10 years aging at 25°C	±30 to 50	ppm
2.4	Temperature Stability	Temperature range only	±10 to 20	ppm

#### 3.0 POWER SUPPLY

Line	Parameter	Test Condition	Value	Unit
3.1	Supply Voltage (VDD)	With a tolerance of ±10%	3.3	V
3.2	Supply Voltage (VDD)	With a tolerance of ±5%	2.5	V
3.3	Supply Current	For LVCMOS	20 max	mA
3.4	Supply Current	For LVPECL	40 max	mA
3.5	Supply Current	For LVDS	35 max	mA

**4.0 OUTPUT CHARACTERISTICS - CMOS (UP TO 200 MHz)**

Line	Parameter	Test Condition	Value	Unit
4.1	Output	LVCMOS		
4.2	Output Voltage (Vol)	10pF load	10 max	%VDD
4.3	Output Voltage (Voh)	10pF load	90 min	%VDD
4.4	Duty Cycle	@ 50% VDD	48 to 52	%
4.5	Output Load		15 max	pF
4.6	Rise Time/Fall Time	90%/10%	3 max	ns
4.7	RMS Phase Jitter	Integrated 12kHz to 20MHz	0.9	ps

**5.0 OUTPUT CHARACTERISTICS - LVPECL ONLY**

Line	Parameter	Test Condition	Value	Unit
5.1	Output	LVPECL		
5.2	Output Voltage (Vol)	50Ω nominal load. (VDD - 1.6V) max.		
5.3	Output Voltage (Voh)	50Ω nominal load. (VDD - 1.03V) min.		
5.4	Duty Cycle	@ VDD-1.3 V	48 to 52	%
5.5	Output Load	With VDD-2 V	50	Ω
5.6	Rise Time/Fall Time	80%/20%	0.6 max	ns
5.7	RMS Phase Jitter	Integrated 12kHz to 20MHz	0.9	ps

**6.0 OUTPUT CHARACTERISTICS - LVDS ONLY**

Line	Parameter	Test Condition	Value	Unit
6.1	Output	LVDS		
6.2	Differential Output: Voltage Swing (Vod)		350	mV
6.3	Duty Cycle	Measured at 1.25 V	48 to 52	%
6.4	Output Load	RL = 100 Ω / CL = 10 pF		
6.5	Rise Time / Fall Time	RL = 100 Ω / CL = 10 pF	0.6 max	ns
6.6	RMS Phase Jitter	Integrated 12kHz to 20MHz	0.9	ps

**7.0 PIN CONNECTIONS**

Line	Parameter	Description
7.1	Pin 1	E/D* or NC
7.2	Pin 2	E/D* or NC
7.3	Pin 3	GND
7.4	Pin 4	OUTPUT
7.5	Pin 5	COMPLIMENTARY OUTPUT (LVPECL/LVDS only), or E/D*, or NC
7.6	Pin 6	VDD
7.7	* Output Enabled	>70% of VDD on E/D pin, or E/D pin left open (connected to internal pull-up resistor)
7.8	* Output Disabled	<30% of VDD on E/D pin, or E/D pin to GND

**8.0 PRODUCT MARKING**

Line	Parameter	Description
8.1	Top line	[R #####] Part identifier
8.2	Middle line	[#####] Part information
8.3	Bottom line	[o FYWW] Pin 1, Manufacturing code, Year code* and Week code**
8.4	* Year code	A = 2010, B = 2011, C = 2012, D = 2013, ... Z = 2035
8.5	** Week Code	WW = 01 = Week of first Monday of the year

**9.0 ENVIRONMENTAL SPECIFICATION**

Line	Parameter	Description
9.1	Mechanical Shock	MIL-STD-883, Method 2002
9.2	Storage Temperature Range	-55 to 125 °C
9.3	Humidity	After 48 hours at 85 °C±2 °C 85 % relative humidity non-condensing
9.4	Thermal Shock	MIL-STD-883, Method 1011
9.5	Vibration	MIL-STD-883, Method 2007
9.6	Gross and Fine Leak	MIL-STD-883, Method 1014

**10.0 MANUFACTURING INFORMATION**

Line	Parameter	Description
10.1	Packaging Description	Tape and Reel. Standard packing quantity is 2000 per reel
10.2	Reflow	Solder reflow process as per attached profile

**Drawing Name: XO/VCXO 7050 Model Drawing**

**PACKAGE A**

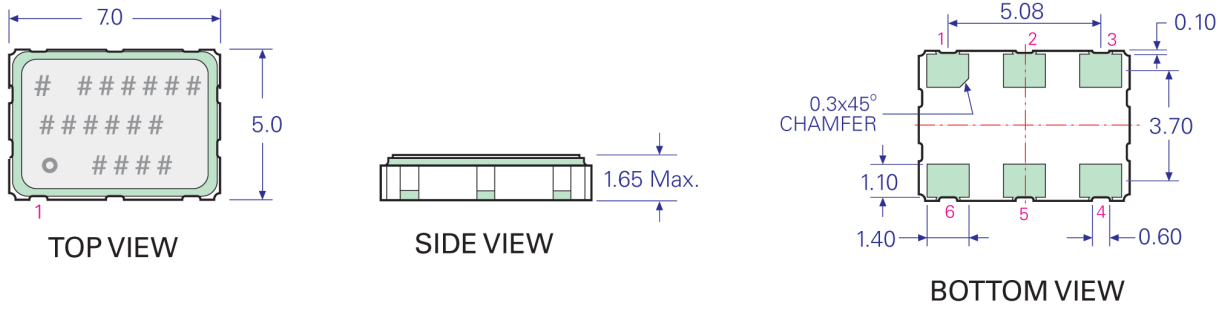

**PACKAGE B**

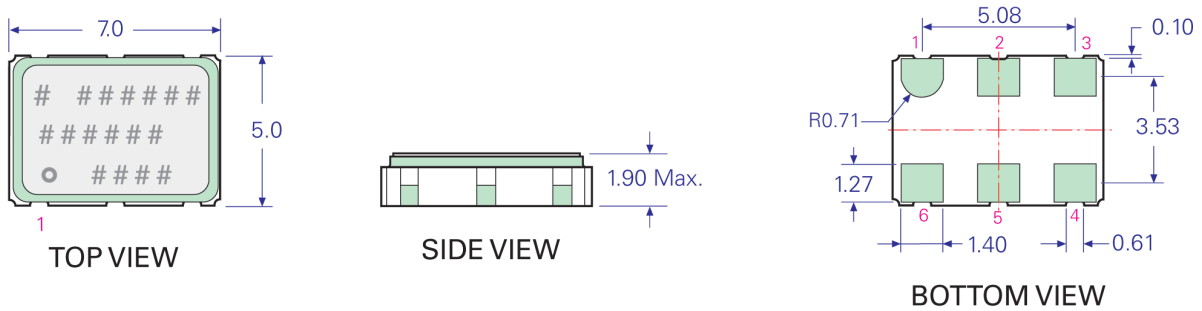

**PACKAGE C**

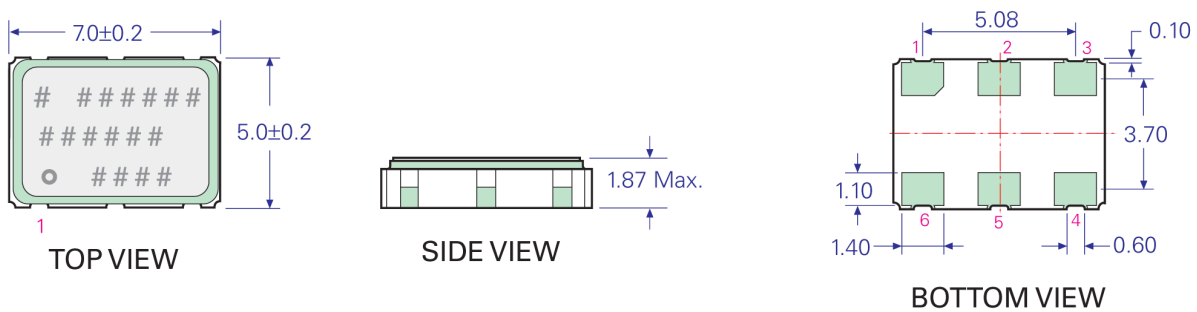

**RECOMMENDED PAD LAYOUT - TOP VIEW**

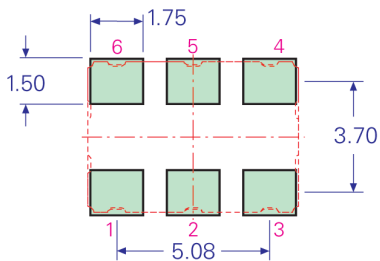

**NOTE:**

1. PIN CONNECTIONS AND MARKING INFORMATION ARE DETAILED IN THE SPECIFICATION.

TITLE: XO/VCXO 7050 MODEL

FILENAME: CAT207

Tolerance:

RELATED DRAWINGS:

REVISION: H

XX =

X.X = ±0.15

X.XX = ±0.10

X.XXX =

X° =

Hole =

DATE: 12-Sep11

SCALE: 5 : 1

Millimetres



©2009 Rakon Limited

**Drawing Name: XO/VCXO 7050 Series Test Circuit**

LVCMOS TEST CIRCUIT:

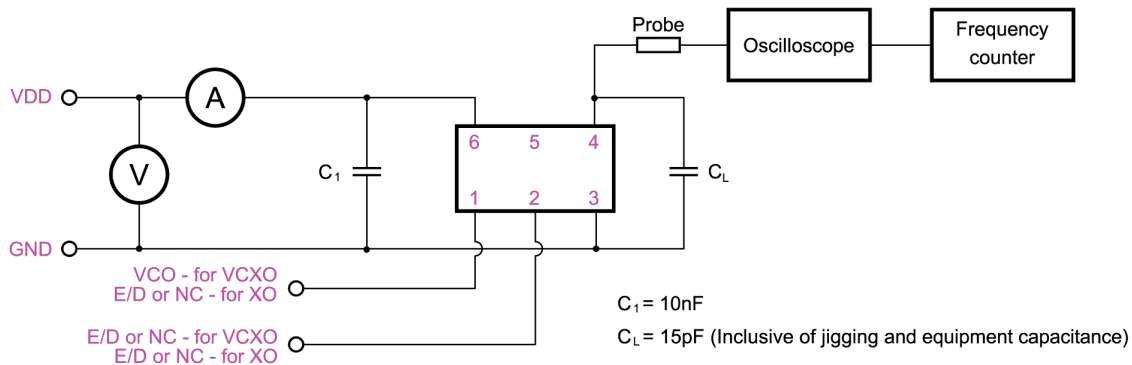

LVPECL TEST CIRCUIT:

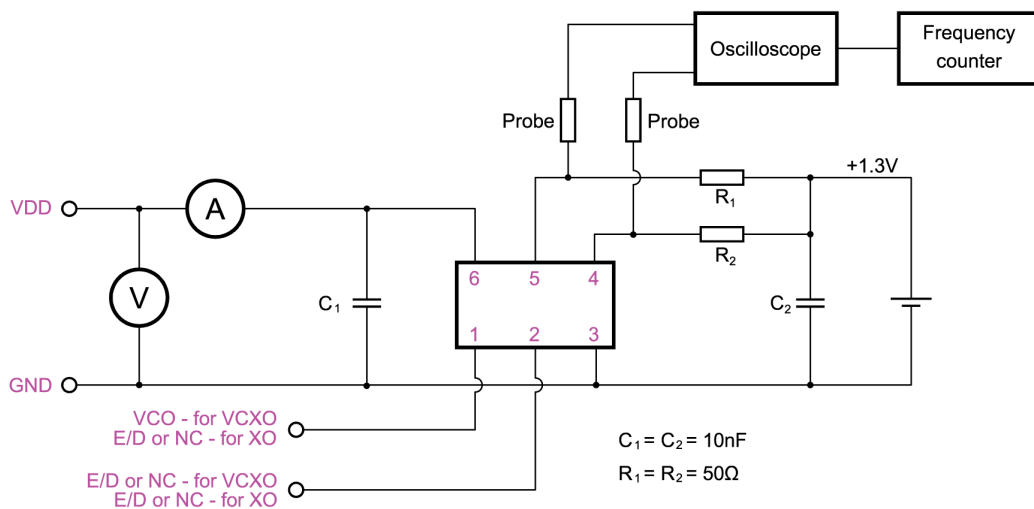

LVDS TEST CIRCUIT:

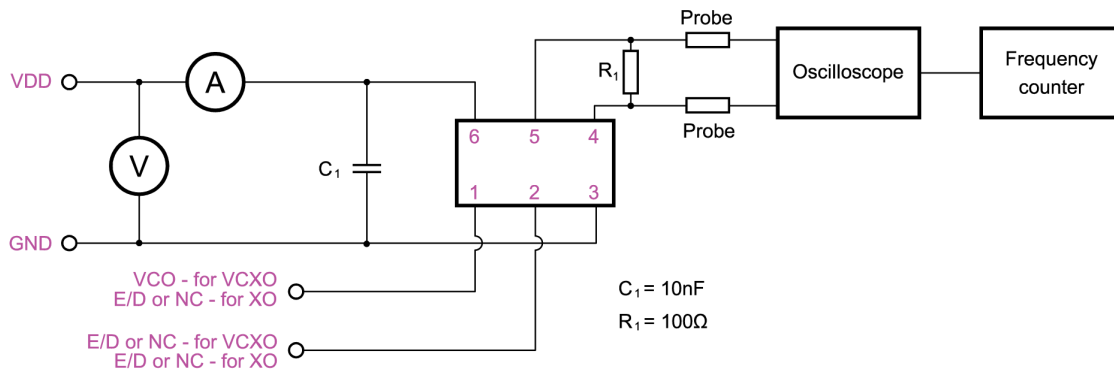

TITLE: XO/VCXO 7050 SERIES TEST CIRCUIT

FILENAME: CAT088

RELATED DRAWINGS:

REVISION: E

DATE: 05-Sep-11

SCALE: 1 : 1

Millimetres

**rakon**

© 2009 Rakon Limited

**Drawing Name: XO/VCXO 7050 Series Tape & Reel**

TAPE DETAIL (SCALE 2 : 1)

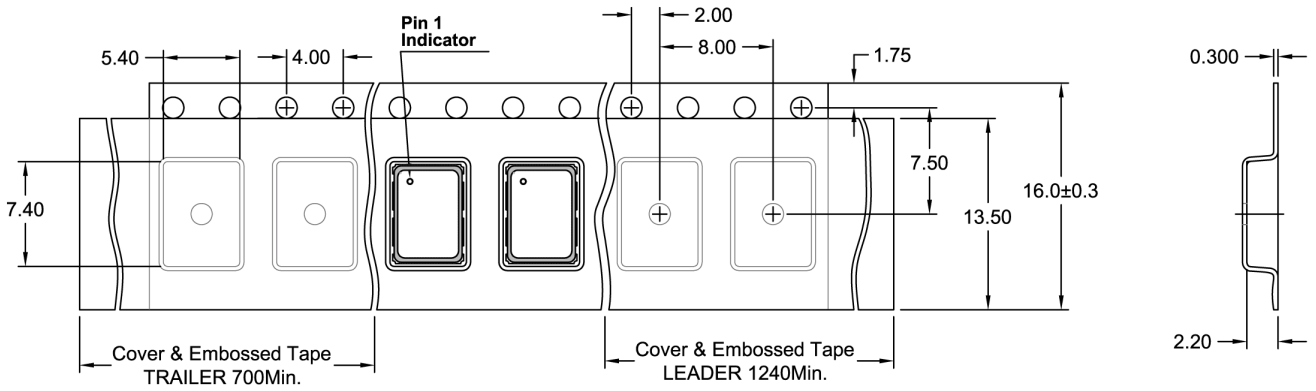

REEL DETAIL (SCALE 1 : 2.5)

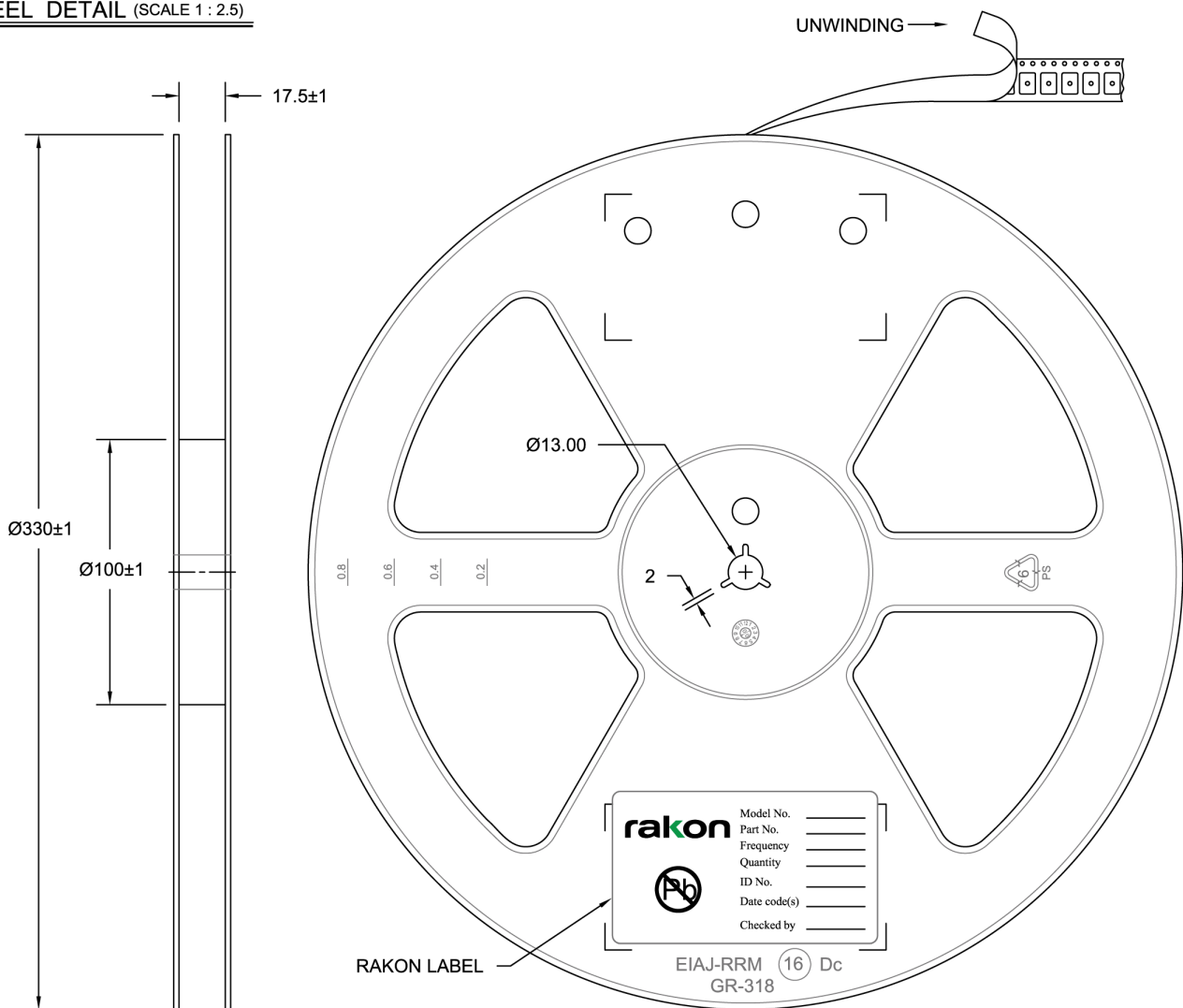

TITLE: XO/VCXO 7050 SERIES TAPE & REEL

RELATED DRAWINGS:

FILENAME: CAT032

REVISION: D

DATE: 05-Sep-11

SCALE: 2 : 1

Millimetres

TOLERANCES:

XX = ±0.5  
 X.X = ±0.2  
 X.XX = ±0.10  
 X.XXX = ±0.05  
 X° =  
 Hole =

**rakon**

© 2009 Rakon Limited

**Drawing Name: Pb-Free Reflow**

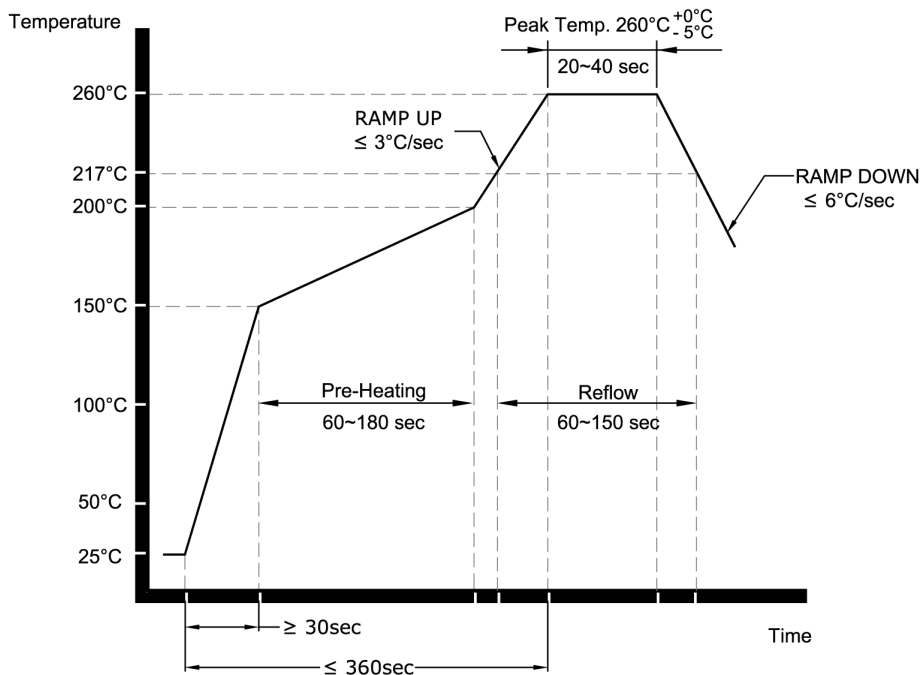

**NOTE:**

The product has been tested to withstand the Reflow Profile shown. The Reflow Profile used to solder Rakon products is determined by the solder paste Manufacturer's specification. It is recommended that the Reflow Profile used does not exceed the one shown above.

TITLE: Pb-FREE REFLOW

FILENAME: CAT541

RELATED DRAWINGS:

REVISION: B

DATE: 05-Sep-11

SCALE: NTS

Millimetres



© 2009 Rakon Limited