

RTN5032A

The RTN5032A is a Stratum 3 ultra-stable TCXO offering up to ± 100 ppb frequency versus temperature stability. It is powered by Rakon's proprietary Niku™ ASIC and XMEMS® resonator. Combined, these technologies bring an extended frequency range of 10 to 100 MHz, a wider operating temperature range of -40 to 105°C, and a low acceleration sensitivity (g-sensitivity) of 0.2 ppb/g. The RTN5032A boasts unparalleled close-in phase noise (-125 dBc/Hz at 100 Hz, 38.88 MHz) and a floor noise as low as -170 dBc/Hz, making it the oscillator of choice for applications requiring high frequency, low noise, low RMS jitter and high stability reference clocks.

For today's high-demanding applications, where precision and reliability of reference clocks are vital, the Niku™ RTN5032A ensures consistent and accurate performance as a result of a combination of compact design, rigorous manufacturing processes, and high-resolution testing methods. This ultra stable TCXO addresses a wide range of applications, including 5G and 5G Advanced radio heads and small cells, AI computing/data centres, precision positioning, aerospace and defence, satellite terminals, automotive/V2X and Industry 5.0.

Key specifications

- Package: 5.0 x 3.2 x 1.85 mm, 10-pad, SMD
- Frequency: 10 to 100 MHz
- Operating temperature: -40 to 105°C
- Frequency stability (FvT): ± 100 ppb
- Long term stability: ± 4.6 ppm/20 yr
- Floor noise: -170 dBc/Hz @ 38.88 MHz
- Acceleration sensitivity: 0.2 ppb/g
- Output waveform: Clipped sinewave or CMOS
- Voltage supply: 2.5, 3.0, 3.3 and 5 V

Applications

- Cellular networks
- AI computing/Data centres
- Automotive/V2X
- Industry 5.0
- GNSS precision positioning
- Networking
- Precision agriculture
- Defence systems
- Satellite terminals

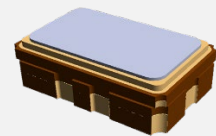

Phase Noise

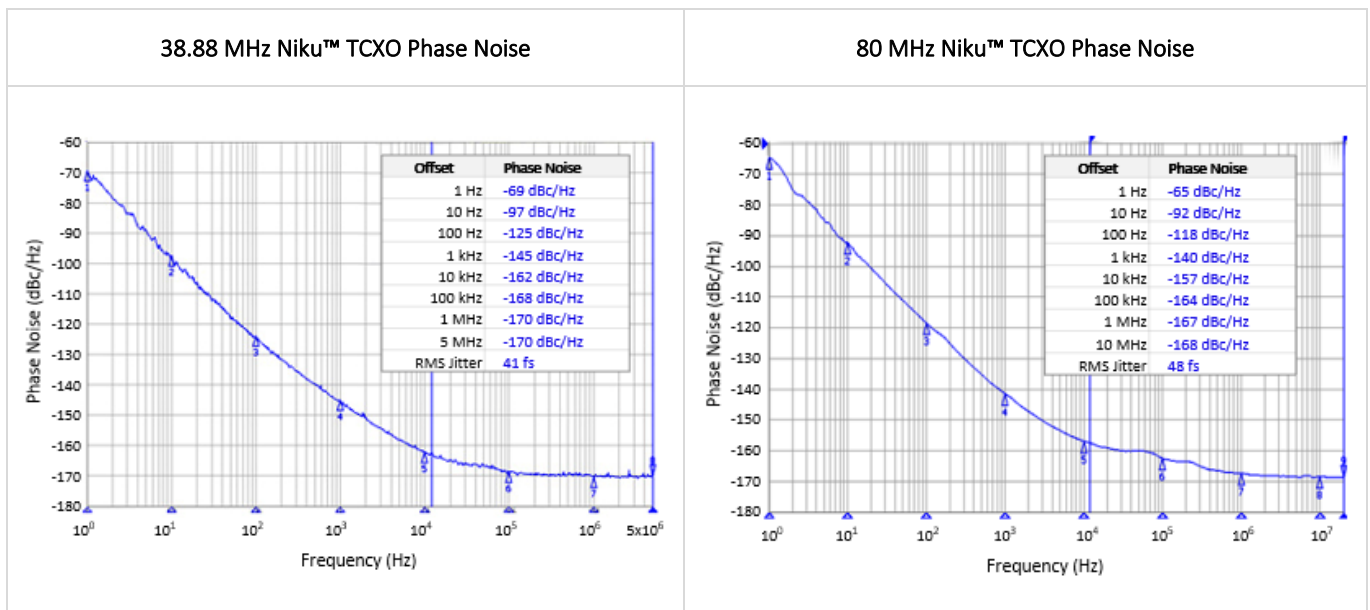

RTN5032A

1.0 Absolute Maximum Rating¹

Parameter	Min.	Max.	Unit	Note
a. Power supply	-0.6	7.0	V	
b. Storage temperature	-55	125	°C	

2.0 Frequency Characteristics²

Parameter	Min.	Typ.	Max.	Unit	Test Condition / Description
a. Nominal frequency (Fn)		10 to 100		MHz	Standard Fn: 10, 19.2, 19.44, 20, 38.4, 38.88, 40, 50 and 80MHz
b. Frequency calibration			±1	ppm	Offset from nominal frequency measured at 25°C ±2°C, Vc=1.5/1.65V
c. Reflow shift			±1	ppm	Two consecutive reflows as per the attached profile after 2 hours of relaxation at 25°C
d. Temperature range	-40		+105	°C	The operating temperature range over which the frequency stability is measured
e. Frequency stability over temperature (FvT) ^{3, 4}			±100 ±120 ±200 ±280	ppb	-40 to 85°C (for 10 to 55 MHz) -40 to 95°C (for 10 to 55 MHz) -40 to 105°C (for 10 to 55 MHz) -40 to 105°C (for 55 to 100 MHz)
f. Frequency slope ^{3, 4}			±20 ±25 ±50 ±100	ppb/°C	-40 to 85°C (for 10 to 55 MHz) -40 to 95°C (for 10 to 55 MHz) -40 to 105°C (for 10 to 55 MHz) -40 to 95°C (for 55 to 100 MHz) Minimum of one frequency reading every 2°C over the operating temperature range
g. Hysteresis ⁵		±50		ppb	Operating temperature range (Optional spec)
h. Sensitivity to supply voltage variations		±25	±50	ppb	Supply voltage varied ±5% at 25°C
i. Sensitivity to load variations		±25	±50	ppb	±10% load change at 25°C ⁶
j. Long term stability (at 25°C)		±4.0	±10 ±1 ±3 ±4.6	ppb ppm ppm ppm	Per day, after 30 days of continuous operation 1 year 10 years 20 years, all-cause stability
k. Acceleration sensitivity			0.8	ppb/g	Gamma vector, 3 -axes, 30-1500Hz

¹ Operating beyond this limit may result in change or permanent damage to the device.

² For optimal frequency stability, the output load must be stable over temperature. Buffer may be recommended depending on the application.

³ Referenced to the midpoint between minimum and maximum frequency value over the specified temperature range. The temperature varied at a maximum of 1°C per minute.

⁴ Parts should be shielded from drafts causing unexpected thermal gradients. Temperature changes due to ambient air currents on the oscillator can lead to short-term frequency drift

⁵ The hysteresis performance is related to the filter capacitance to be used. Filter options refer to the RAV section.

⁶ Measurement load condition is 10kΩ//10pF for CS and 15pF for CMOS

3.0 Power Supply

Parameter	Min.	Typ.	Max.	Unit	Test Condition / Description
a. Supply voltage (V_{DD})		2.5 to 5.0		V	Nominal V_{DD} ($\pm 5\%$). Standard values are 2.5V, 3.0V, 3.3V and 5V
b. Current (Clipped Sinewave)		9.4 15 18		mA	At nominal 3.3V V_{DD} , 10MHz at 10pF//10k Ω 40MHz at 10pF//10k Ω 80MHz at 5pF
c. Current (CMOS)		10 17 24		mA	At nominal 3.3V V_{DD} , 10MHz at 15pF 40MHz at 15pF 80MHz at 5pF

4.0 Control Voltage (V_c)

Parameter	Min.	Typ.	Max.	Unit	Test Condition / Description
a. Control voltage range ⁷	0.25		2.25	V	$V_{DD} \geq 2.5V$
b. Control voltage range ⁷	0.5		2.5	V	$V_{DD} \geq 3.0V$
c. Control voltage range ⁷	0.65		2.65	V	$V_{DD} \geq 3.3V$
d. Frequency tuning	± 5		± 10	ppm	Reference to frequency at $V_c=1.25/1.5/1.65V$
e. Frequency tuning linearity			10	%	Deviation from straight line curve fit
f. Slope					Positive
g. Modulation bandwidth		1		Hz	
h. Input impedance	100			k Ω	

5.0 Oscillator Output – Clipped Sinewave⁸

Parameter	Min.	Typ.	Max.	Unit	Test Condition / Description
a. Output waveform					DC coupled clipped sinewave
b. Output voltage level	0.8	1.2		V _{pp}	At minimum supply, 10k Ω //10pF load
c. Start-up time (amplitude)			10	ms	Time taken for output to reach 90% amplitude
d. Output load resistance		10		k Ω	
e. Output load capacitance		10		pF	5pF for $F_n \geq 55MHz$

6.0 Oscillator Output – CMOS⁹

Parameter	Min.	Typ.	Max.	Unit	Test Condition / Description
a. Output voltage level low (V_{OL})			10% V_{DD}	V	
b. Output voltage level high (V_{OH})	80% V_{DD}			V	
c. Rise and fall times time		3		ns	10% to 90% amplitude
d. Duty cycle	40		60		Measured at 50% me.
e. Output load		15		pF	5pF for $F_n \geq 55MHz$
f. Start-up time			10	ms	90% amplitude

⁷ Wider range subject to engineering approval

⁸ This part has a 1.2V regulated CMOS output for better isolation from supply and board noise. It is suitable for driving inputs that require a clipped sinewave signal. If an AC coupled output is required a 10nF capacitor should be placed in series with the output. The nominal load condition is 10k Ω || 10pF (including probe).

⁹ This part has a 2.8V regulated CMOS output for better isolation from supply and board noise. It can be used to drive LVCMOS and LVTTTL inputs as per the JE8D8C.01 standard. The nominal load capacitance is 15pF (including probe).

7.0 Oscillator Output – Temperature Sensor Option

Parameter	Min.	Typ.	Max.	Unit	Test Condition / Description
a. Temperature sensor output voltage		0.95		V	At 25°C
b. Temperature sensor slope		-8		mV/°C	-55 to 105°C range
d. Temperature sensor			10	pF	

Parameter	Min.	Typ.	Max.	Unit	Test Condition / Description
a. Temperature sensor output voltage		0.95		V	At 25°C
b. Temperature sensor slope		-8		mV/°C	-55 to 105°C range
c. Temperature sensor			10	pF	

8.0 Tri-State Control¹⁰

Parameter	Min.	Typ.	Max.	Unit	Test Condition / Description
a. Tri-state mode					The device features a tri-state mode which allows the output to be disabled and brought into a high impedance state
b. Tri-state control (pin 3/5), input level low (V_{IL})			20%V _{DD}	V	Device disabled (output in high impedance state)
c. Tri-state control (pin 3/5), input level high (V_{IH})	80%V _{DD}			V	Device enabled (operating)

9.0 SSB Phase Noise (38.8 MHz, Typical value at 25°C)

Parameter	Min.	Typ.	Max.	Unit	Test Condition / Description
1Hz offset		-69		dBc/Hz	
10Hz offset		-97		dBc/Hz	
100Hz offset		-125		dBc/Hz	
1kHz offset		-145		dBc/Hz	
10kHz offset		-162		dBc/Hz	
100kHz offset		-168		dBc/Hz	
1MHz offset		-170		dBc/Hz	
5MHz offset		-170		dBc/Hz	
RMS phase Jitter		41		fs	

10.0 Root Allan Variance (Typical value at 25°C)

Parameter	Min.	Max.	Unit	Test Condition / Description
a. Root Allan Variance (RAV)		3×10^{-11} 4×10^{-11} 8×10^{-11} 1×10^{-10}		tau = 0.1s tau = 1.0s tau = 10s tau = 100s

¹⁰ The tri-state control (enable) input pin has an internal 100kΩ pull up resistor which allows it to be left unconnected if not used. When in tri-state mode, the output stage is disabled, but the oscillator and compensation circuit are still active.

11.0 Marking

Parameter	Test Condition / Description
a. Type	Engraved
b. Line 1	[R FFFF YM] Rakon identifier R, Frequency FFFF (M=MHz, e.g. 19M4=19.44MHz), Year Y (A=2010, B=2011, ...), Month M (1=Jan, 2=Feb, ..., A=Oct, B=Nov, C=Dec)
c. Line 2	[• XXX LLL] Pin 1 identifier •, Internal code XXX, Lot code LLL

12.0 Manufacturing Information

Parameter	Test Condition / Description
a. Reflow	Reflow profile as per IPC/JEDEC J-STD-020E (see drawing)
b. Packaging description	Tape & Reel as per EIA-481-E (see drawing)
c. Net weight	0.08g/pc

13.0 Environmental Specification¹¹

Parameter	Test Condition / Description
a. RoHS compliant	Parts are fully compliant with the European Union directives 2011/65/EU and 2015/863/EU (amending annex II to directive 2011/65/EU) on the restriction of the use of certain hazardous substances in electrical and electronic equipment
b. Solderability	JESD22-B102. Method 2, precondition 150°C, 16 hours
c. Latch up	EIA/JESD78, tested at room temperature and maximum ambient operating temperature
d. Electrostatic discharge (ESD)	Human Body Model (HBM), JS-001-2012, ≥ 2000V Charged Device Model (CDM), JS-002-2022, corner pins ≥ 1000V, middle pins ≥ 500V
e. High temperature storage	JESD22-A103, 1000 hours at 150°C, unbiased
f. Low temperature storage	JESD22-A119, 1000 hours at -55°C, unbiased
g. Thermal shock	MIL-STD-883 Method 1011, 15 cycles from -55°C to 125°C
h. Temperature humidity bias	EIA/JESD22-A101, +85°C / 85% RH, 1008 hours, at max. Vcc
i. Temperature cycling	JESD22-A104, 1000 cycles, -55°C to +125°C, non-operating, 5 to 10 minutes soak
j. High temperature operating life	JESD22-A108D, +125°C, 1008 hours, at max. Vcc
k. Monitored ageing	MIL-PRF-55310F, 1000 hours at +85°C
l. Mechanical shock	JESD22-B-104, 1500g peak, 0.5ms pulse duration, 5 pulses in each of 6 directions
m. Mechanical vibration	JESD22-B-103, 20g peak acceleration, 10-2000Hz, 4 minutes sweep, 4 sweeps x 3 axes

¹¹ For all relevant tests the units are pre-conditioned as per JESD22-A113 (5 temperature cycles -40°C to +60°C + bake for 24 hours at T = +125°C + moisture soak for 168 hours at +85°C / 85% RH + 3x reflow at TMAX = +260°C).

14.0 Model Outline

MODEL DRAWING

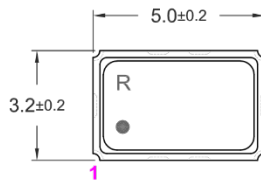

TOP VIEW



FRONT VIEW



SIDE VIEW

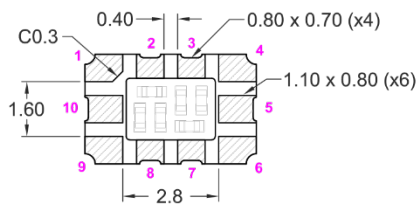

BOTTOM VIEW

Pin Connections

Pin	Connections
1	Do not connect / Control Voltage (Vc)
2, 7, 8, 10	Do not connect
3	Do not connect / Tri-state (Enable) / T-sensor (V _{TEMP})
4	GND
5	Do not connect / Tri-state (Enable) / T-sensor (V _{TEMP})
6	RF Output
9	Supply Voltage (Vcc)

RECOMMENDED PAD LAYOUT - TOP VIEW

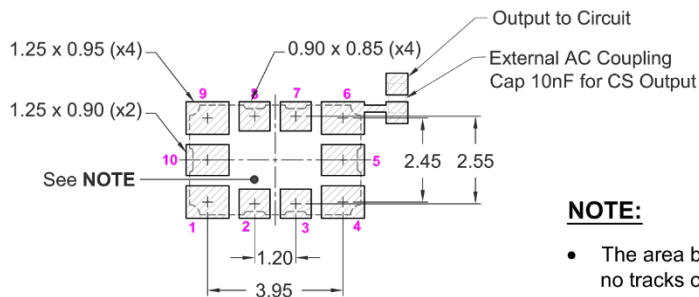

NOTE:

- The area between the pads is a keep-out area, no tracks or ground plane allowed on any layer.

TITLE: RTN5032A MODEL (10 Pad)

RELATED DRAWINGS:

FILENAME: CAT1631

REVISION: A

DATE: 10-Apr-2024

SCALE: 5 : 1

Millimetres

TOLERANCES:

XX =

X.X = ±0.2

X.XX = ±0.10

X.XXX =

X° =

Hole =

15.0 3D Model

Parameter	Test Condition / Description
a. Package size	5.0 x 3.2 x 1.85 mm
b. STEP file	RTN5032A 10-pad 3D model To open or view the STP file, you will need to import it into one of the following software programs: Autodesk Fusion 360, CATIA, SolidWorks, Solid Edge, TurboCAD, Kubotek KeyCreator, FreeCAD, ABViewer, ShareCAD, or eMachineShop.

16.0 Test Circuit

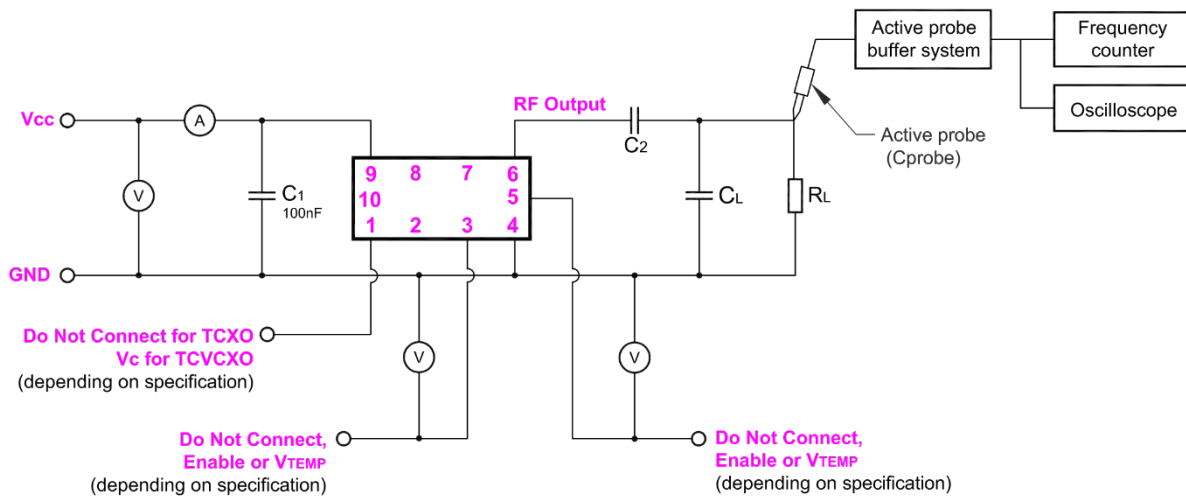

Output Load	C ₂	C _L	R _L
Clipped Sinewave	* 10 nF (AC coupled) * 0 (DC coupled)	10 pF (10 to 55 MHz) 5 pF (55 to 100 MHz)	10 kΩ
CMOS	N / A	15 pF (10 to 55 MHz) 5 pF (55 to 100 MHz)	∞

TITLE: NIKU™ RTN5032 TEST CIRCUIT (CS and CMOS, 10 Pad)

FILENAME: CAT1625

TOLERANCES:

RELATED DRAWINGS:

REVISION: A

XX =

DATE: 27-Oct-2023

X.X =

SCALE:

X.XX =

Millimetres

X.XXX =

X° =

Hole =

17.0 Tape and Reel

TAPE DETAILS

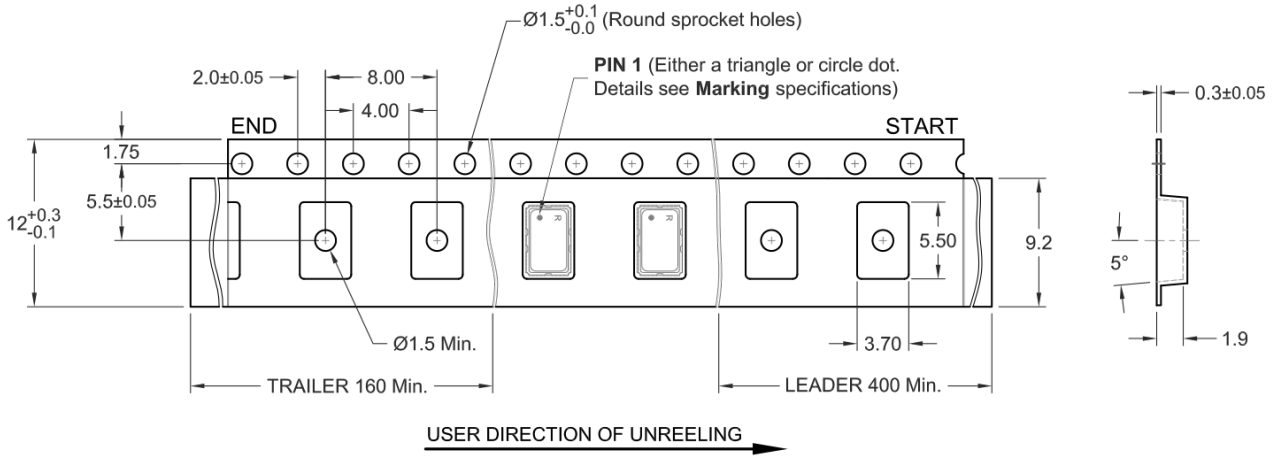

REEL DETAILS

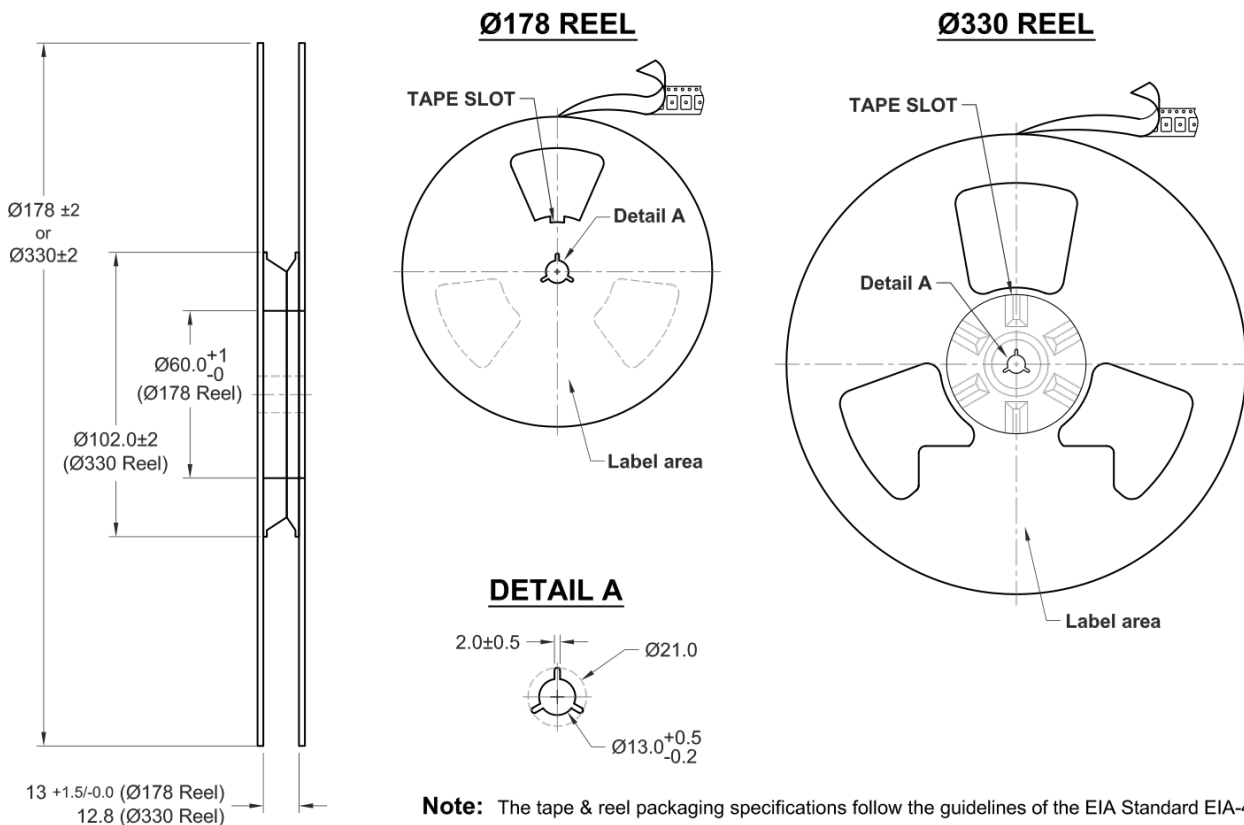

TITLE: RTN5032 SERIES TAPE & REEL

FILENAME: CAT1590

TOLERANCES:

RELATED DRAWINGS:

REVISION: A

XX = ± 1
 X.X = ± 0.2
 X.XX = ± 0.1
 X.XXX =
 X° =
 Hole =

DATE: 09-Jun-2022

SCALE:

Millimetres

rakon

© 2022 Rakon Limited

Issue: C, 7 October 2024

Specifications are subject to change without notice.

Copyright © 2023 to 2024 Rakon Limited. All rights reserved

Page 8 of 9

[Contact Us](#)

18.0 Reflow

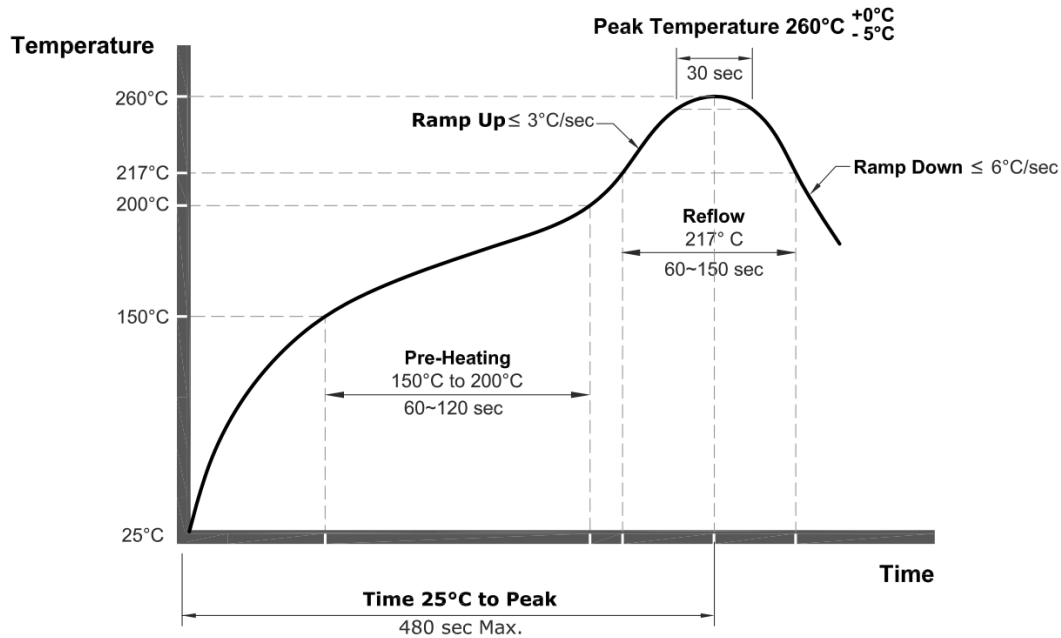

Note:

- The Pb-free Reflow follows the guidelines of IPC/JEDC J-STD-020.
- The product has been tested to withstand the Reflow Profile shown. The Reflow Profile used to solder Rakon products is determined by the solder paste Manufacturer's specification. It is recommended that the Reflow Profile used does not exceed the one shown above.

TITLE: Pb-Free Crystal & Oscillator Reflow (Classification Temperature Tc = 260°C)

FILENAME: CAT541

RELATED DRAWINGS:

REVISION: C

DATE: 16-May-2019

SCALE: NTS

Millimetres

rakon

© 2013 Rakon Limited

19.0 Disclaimer

Parameter	Description
a. Disclaimer	"Samples supplied according to this specification are supplied from our development or pre-production programme and are not qualification approved products. No condition, warranty or representation regarding quality, suitability, performance, life or continuation of supply is given or implied and Warranty in clause 7 of our standard Conditions of Sale is not applicable. The right is reserved to change the design or specification or cease supply without notice." Rakon Limited